

EVOLUTION TALL COLD FRAME



# Instruction Manual



Made in the United Kingdom

Please read all instructions before proceeding



## Tall Cold Frame Instructions

<b>Contents:</b>	<b>Page</b>
Introduction	2-3
Front Assembly	4-6
Rear Assembly	7-10
Frame Assembly	11-13
Base Assembly	14-15
Glazing Part 1	16
Doors Installation	17-20
Rear Panels	21
Lid Assembly	22-26
Anchoring Down / Shelving	27
Glazing Part 2	28
Autovent attachment (optional)	29
Packing List	30-31

**Thank you for purchasing your new Alton cold frame. We recommend you familiarise yourself with the instructions and read all safety information before you commence assembly. This instruction manual is also available online at [www.greenhousepeople.co.uk](http://www.greenhousepeople.co.uk) in the technical help section should you need to reprint it. Should you require any additional advice you can always call us on 01782 385409.**

### **Safety Warning**

- Glass, aluminium and timber can potentially cause injury. Please ensure you wear protective goggles, gloves, headgear and suitable footwear when assembling and glazing the building.
- Please remember that glass is fragile and should be handled with extreme care. Always clear up and dispose of any breakages immediately.
- Do not assemble the cold frame in high winds.
- To minimise the risk of wind damage, try to select as sheltered a site as possible, e.g. beside a hedgerow or garden fence.

### **Additional Considerations**

- You will find it easier to use a large table or workbench to construct the cold frame so that everything is at a accessible height. A garage floor or flat lawn area is a good alternative.
- If you have arranged for someone to build your cold frame for you, please check that all components are included. Most parts are numbered and can be identified by a stamp or removable label. Alternatively, the components can be identified by lengths detailed on the packing list in the back of this booklet.

# Introduction

To build your new cold frame you will need the following tools:

Spirit Level	Pencil
PZ2 Screwdriver Bit	Cordless Screwdriver (2 would be ideal, 1 to drill and 1 to screw)
4mm Drill Bit	7mm Masonry Bit
Hammer Drill	Hammer
Wooden/Rubber Mallet	Tape Measure

There are 5 different types of screws used in the construction. These are as follows, with examples of where to look out for them (quantities shown on page 31):

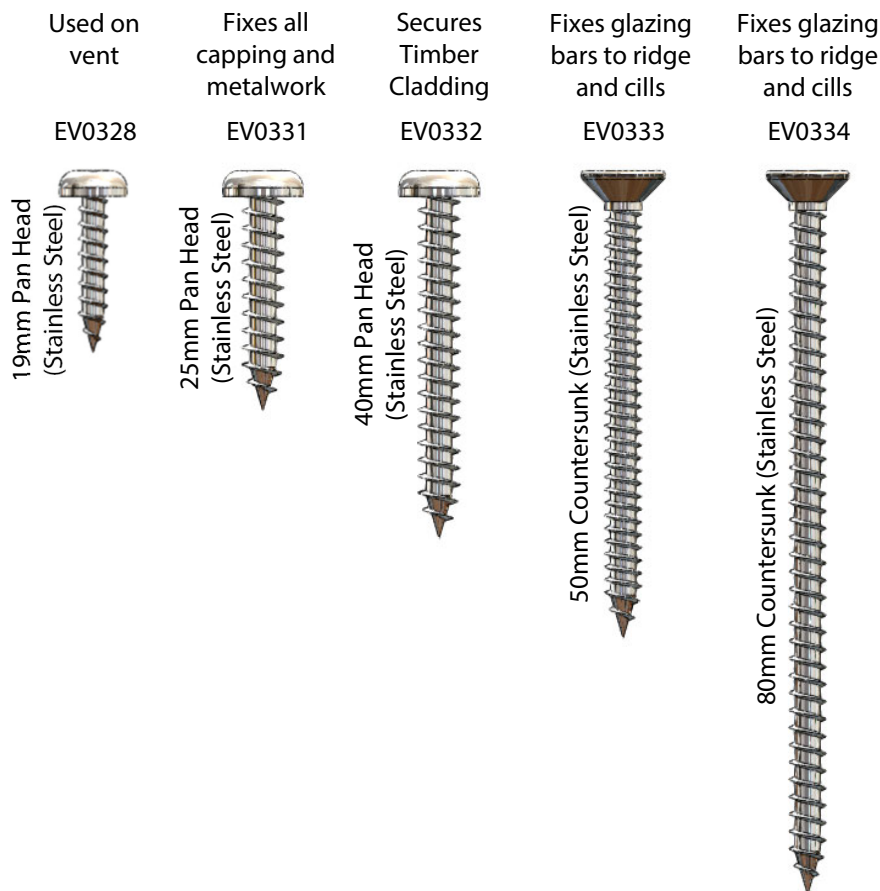

If you are going to treat the cold frame again yourself then it would be best to do it before you begin building the frame.

When screwing through one piece of timber into another it is always recommended to predrill the first piece. This will prevent the timber from splitting which could weaken the structure. A 4mm drill bit has been supplied.

# Front Assembly

To start building your cold frame you need the four components below. First use the drill bit provided to drill a pilot hole through the bottom of the mortises in your front cills 'EV0801'. It is important to always drill pilot holes before inserting a screw to prevent the parts from splitting. This should be as close to the centre of the slot as possible, diagram 1.

**VERY IMPORTANT:** Ensuring they are correctly orientated / mirrored slot the front glazing bars (EV0823) into the mortise holes of the front cills and fix with 50mm countersunk screws. The EV0823's have a deeper rebate on one face to allow for glazing, see below.

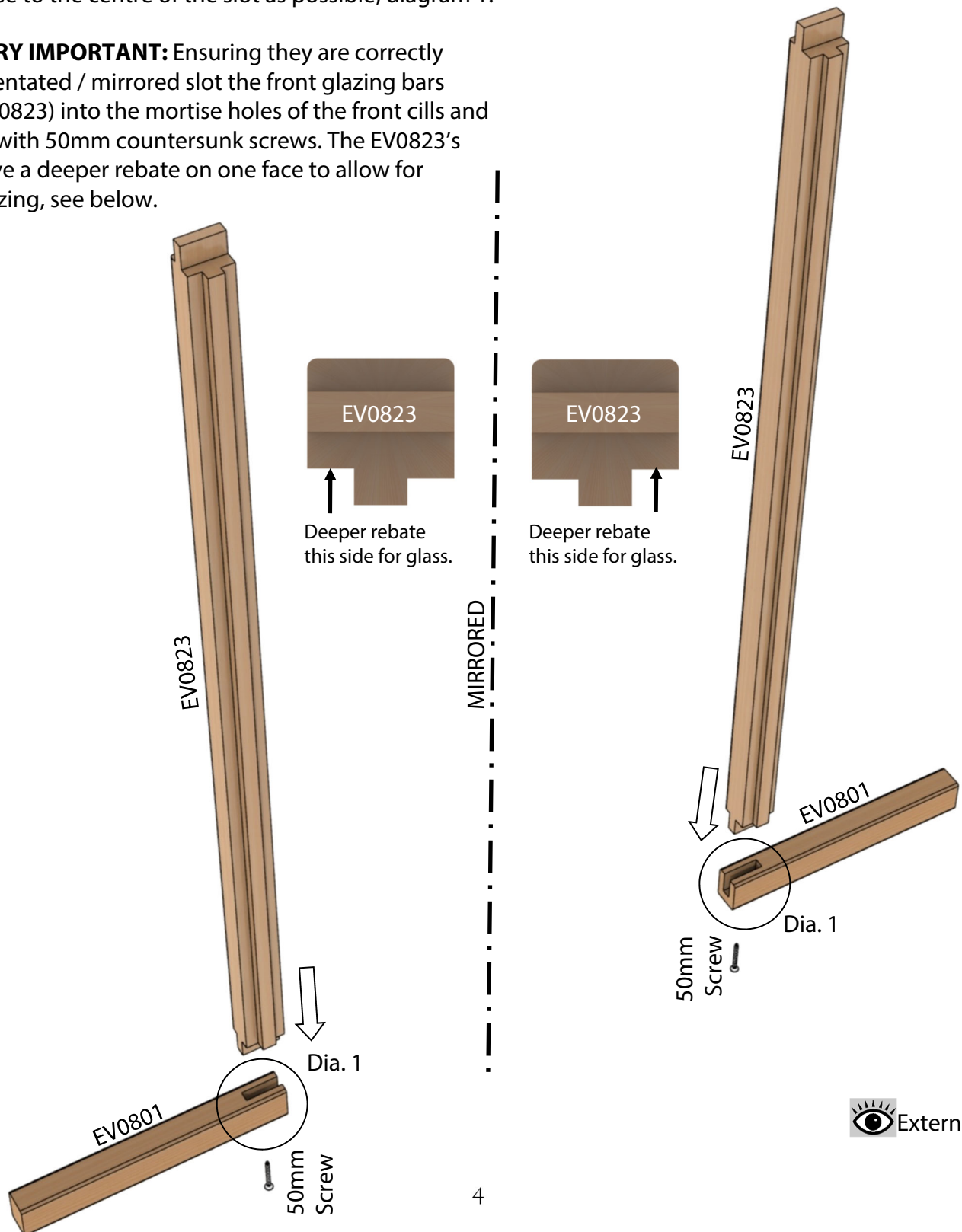
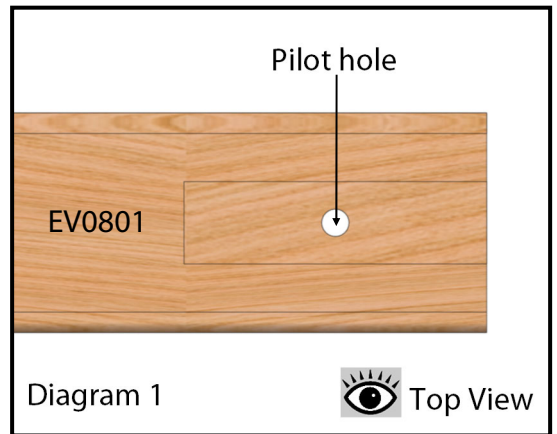

# Front Assembly

Now take the front top rail 'EV0806' and drill pilot holes through the back of the mortise slots as you did before with the cill, diagram 2.

Slot these onto the top of the front glazing bars 'EV0823' and fix with 80mm screws, diagram 3. Check again that the front glazing bars are correctly orientated as you will not be able to amend this later.

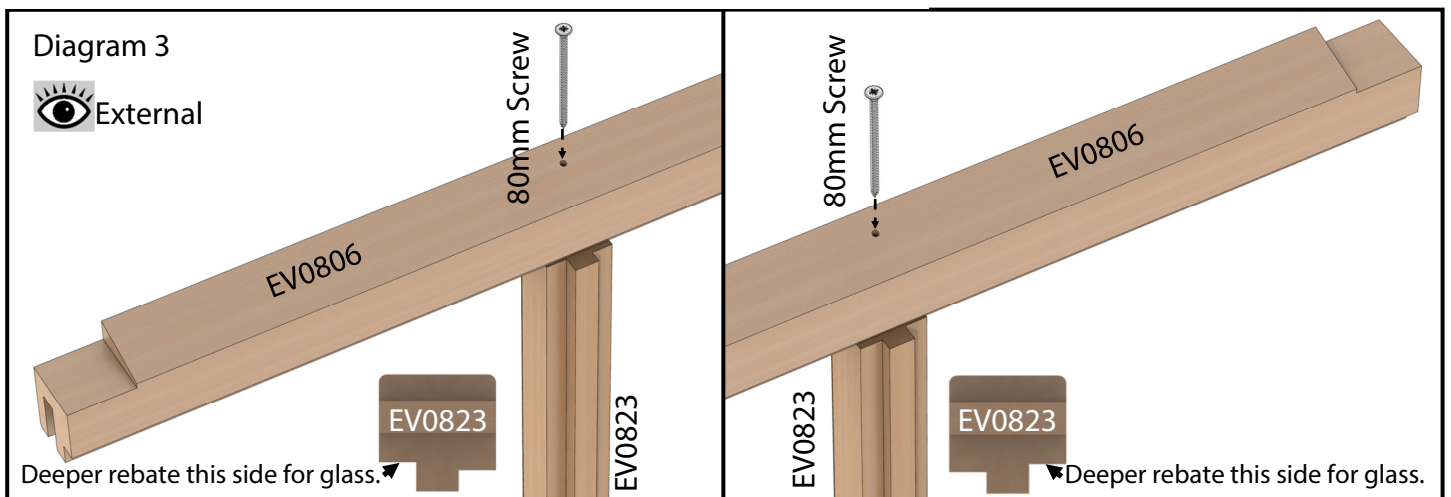
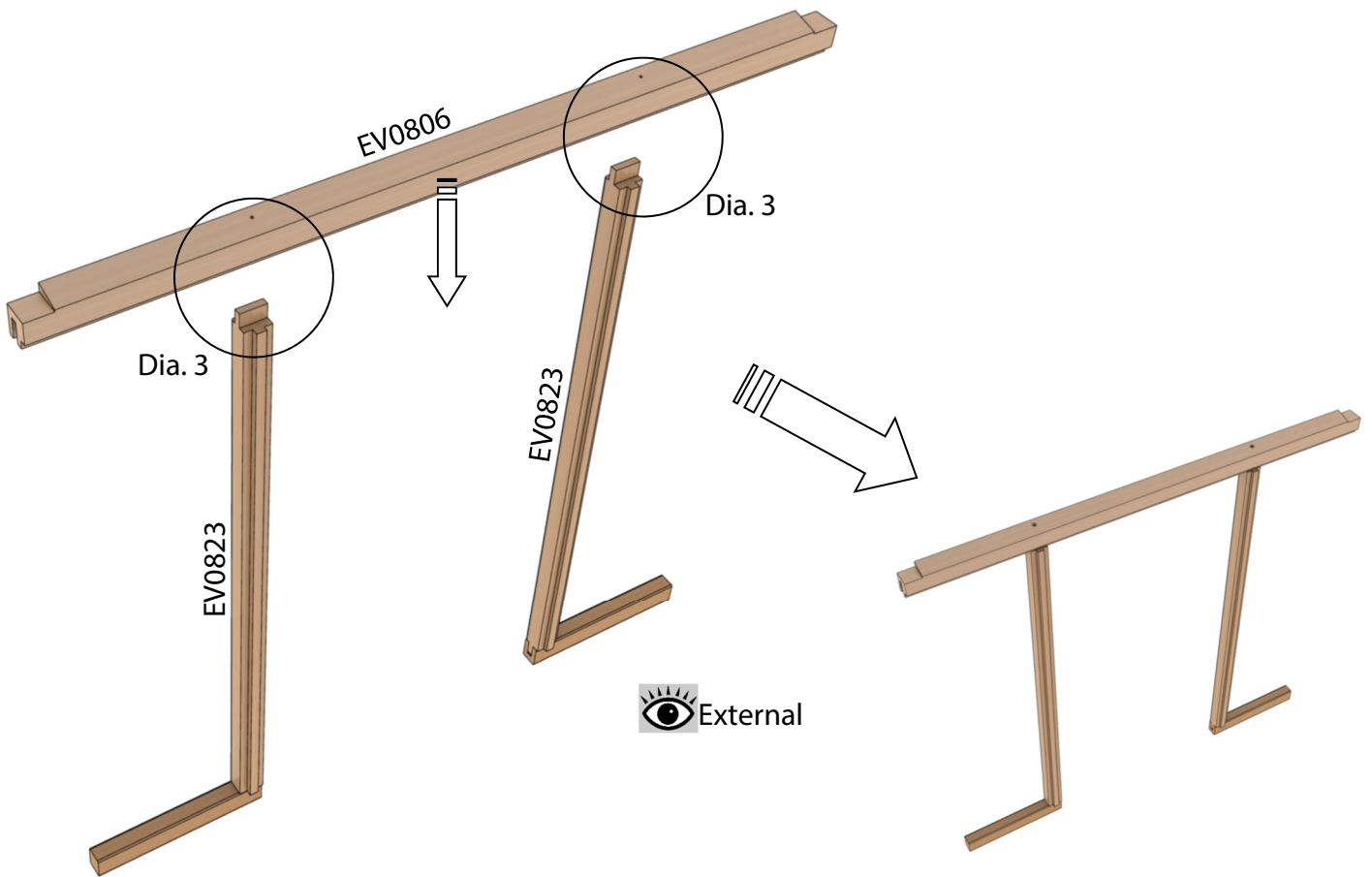
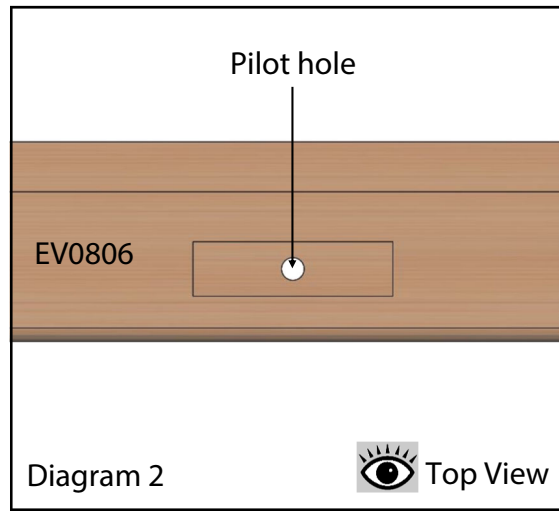

# Front Assembly

You now need to fit the front corner bars 'EV0860 / EV0861', before doing this drill pilot holes in the bottom of the bars, see in diagram 4. This is showing the left hand bar, you will need to measure from the opposite faces for the right hand bar. Make sure the hole in the narrow face lines up with the mortise slot behind.

Once drilled slot the bars onto the assembly. Line the bottom front face up with the front face of the front cill 'EV0801' and fix with an 80mm screw, diagram 5.

Carefully put the front frame to one side, remember the corner tops are not yet secure.

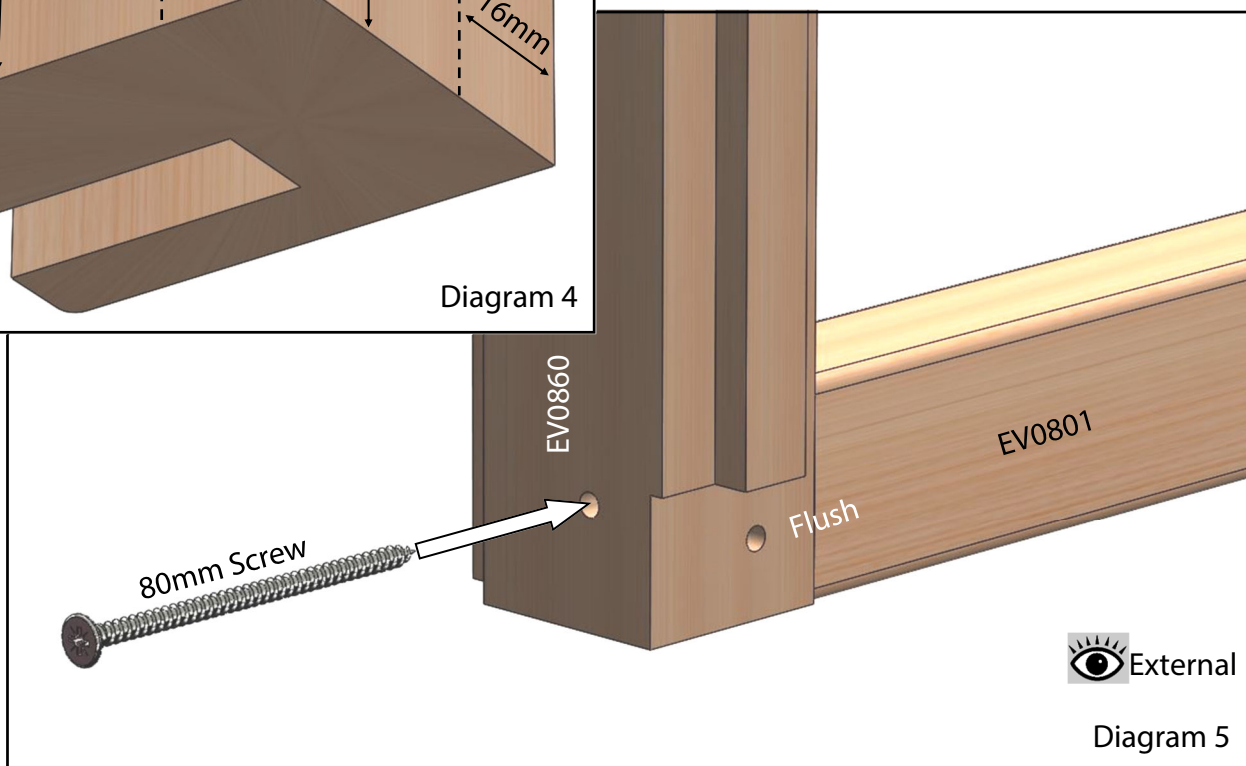
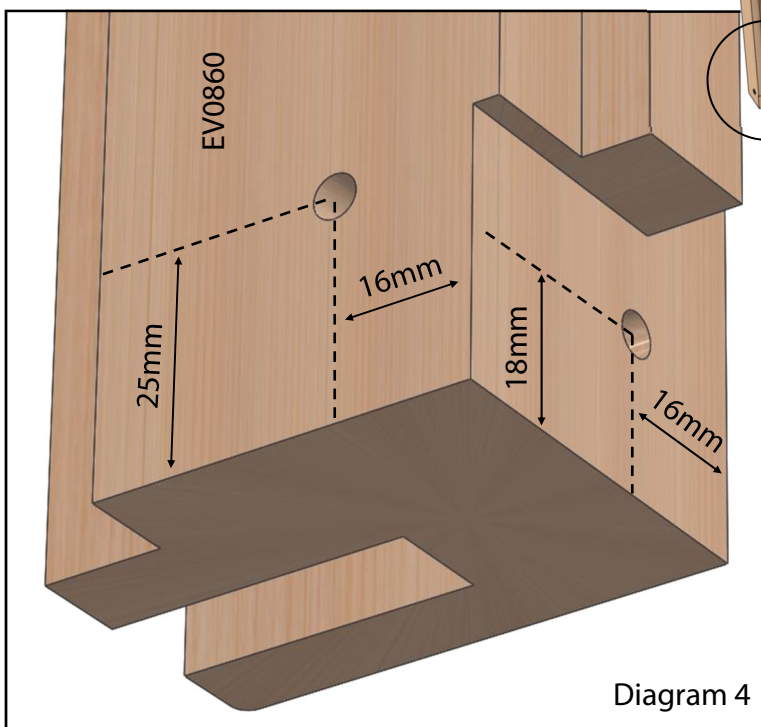
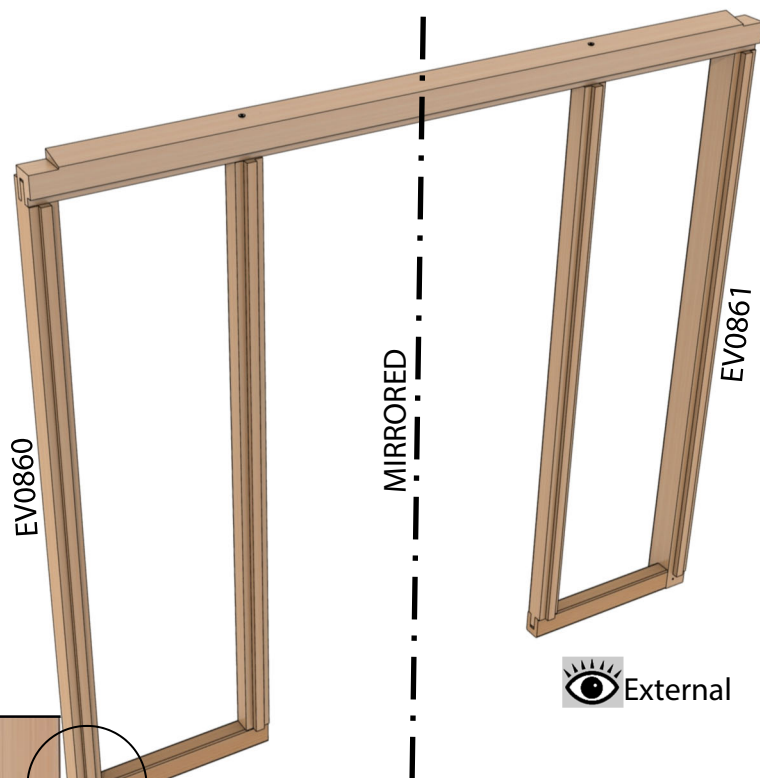

# Rear Assembly

As before drill a pilot hole through the mortise (diagram 6) then slot the rear middle bar 'EV0824' into the rear cill 'EV0800'.

Fix with a 50mm screw.

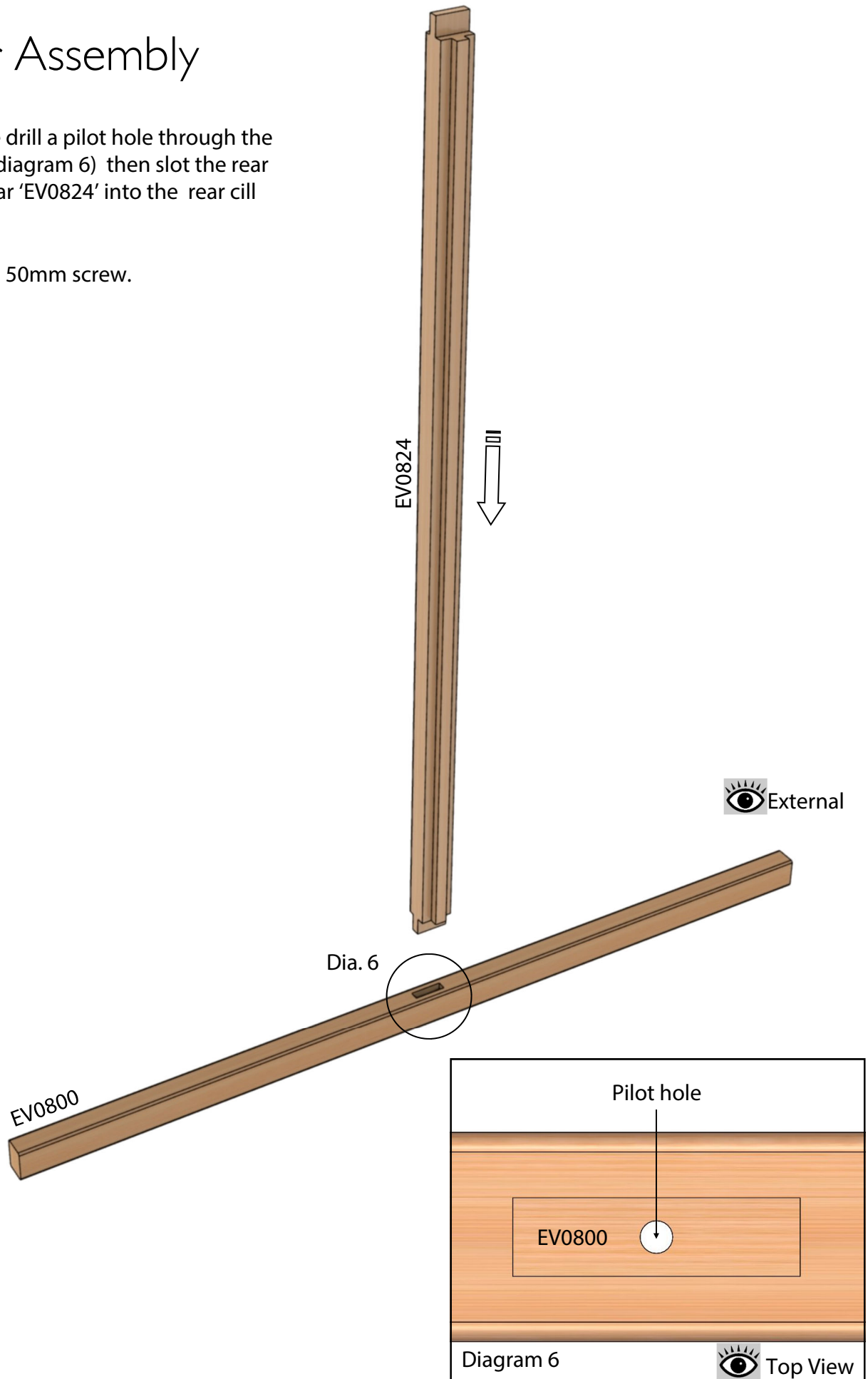

# Rear Assembly

Now drill pilot holes in the rear top rail 'EV0808', diagram 7. This time you need to drill 3 holes, one in each mortise, as shown below.

You can then slot the top rail onto the top of the middle bar 'EV0824'. Make sure you get this the correct way round, the rebates on the middle bar should line up with the rebate in the external face of the top rail.

Then fix with an 80mm screw, diagram 8.

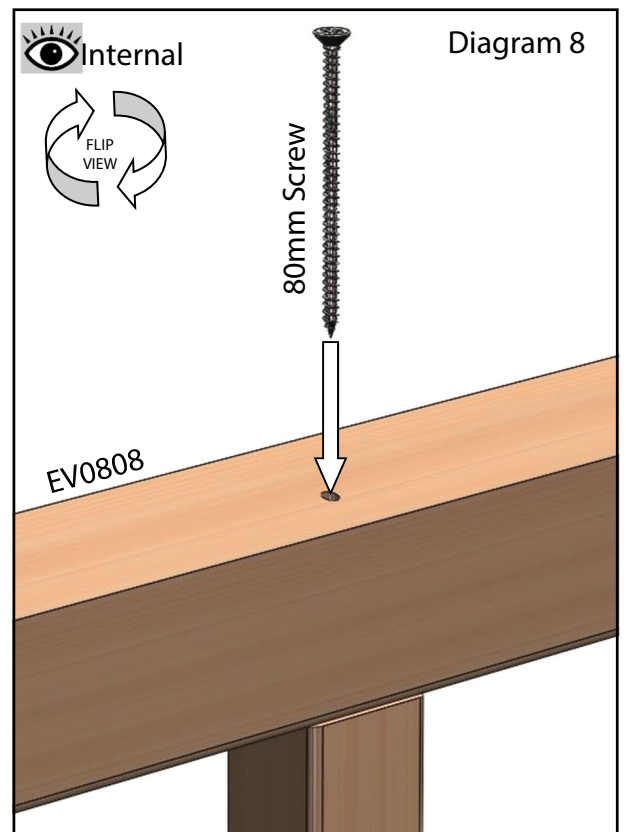
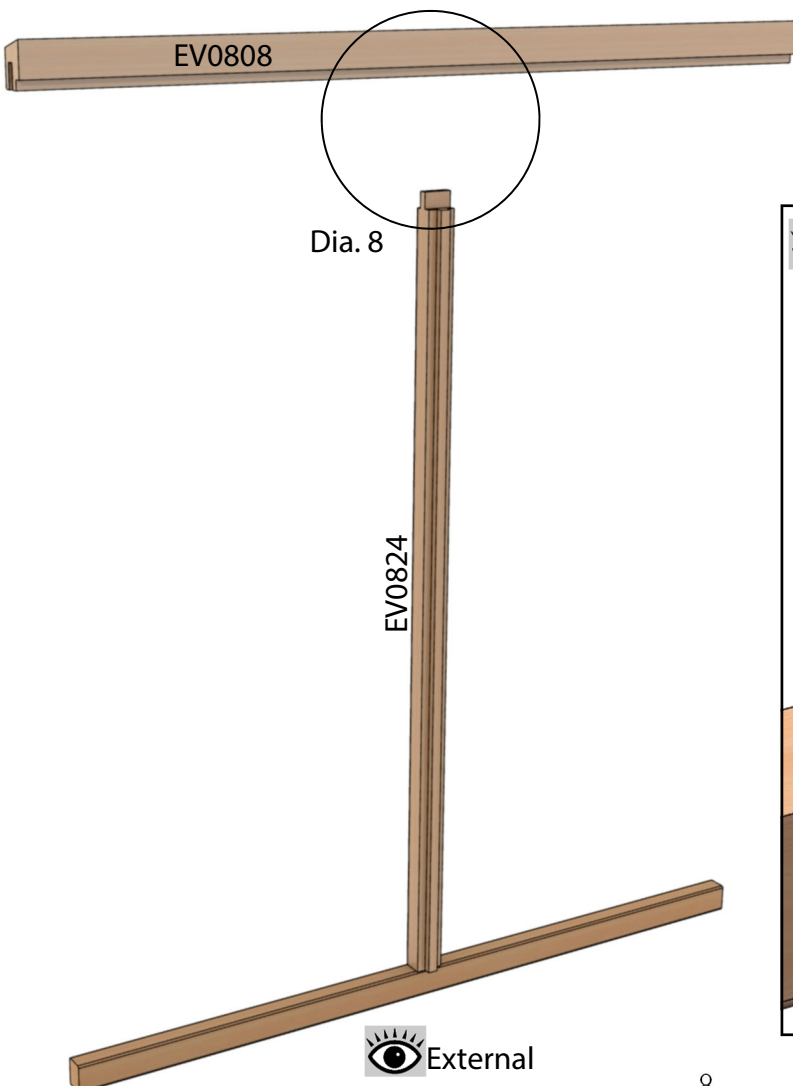
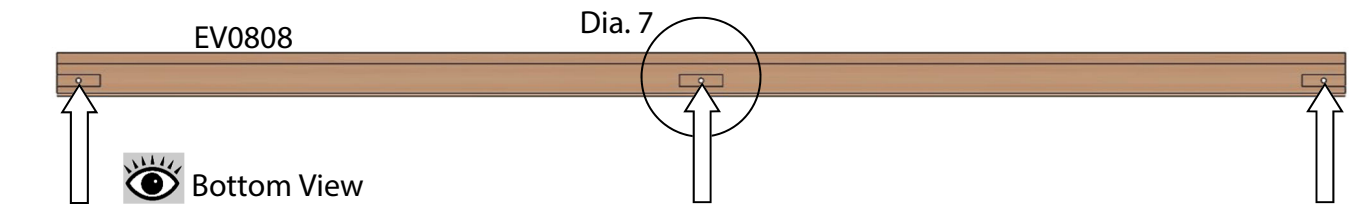
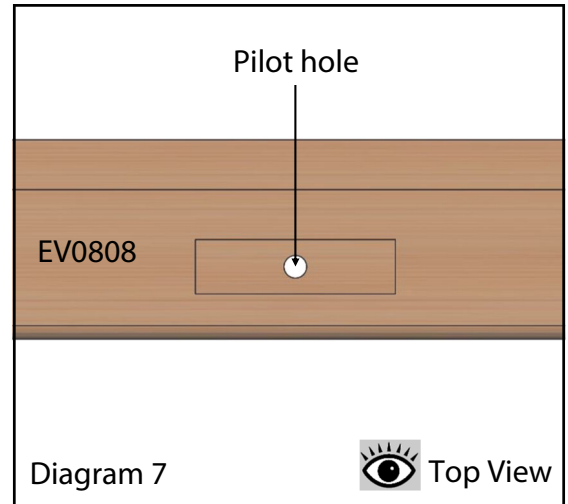

# Rear Assembly

Again before you fit the rear corner bars 'EV0862, EV0863' drill pilot holes as shown in diagram 9.

Slot these onto the rear top rail and fix to the rear cill with 80mm screws, diagram 10.

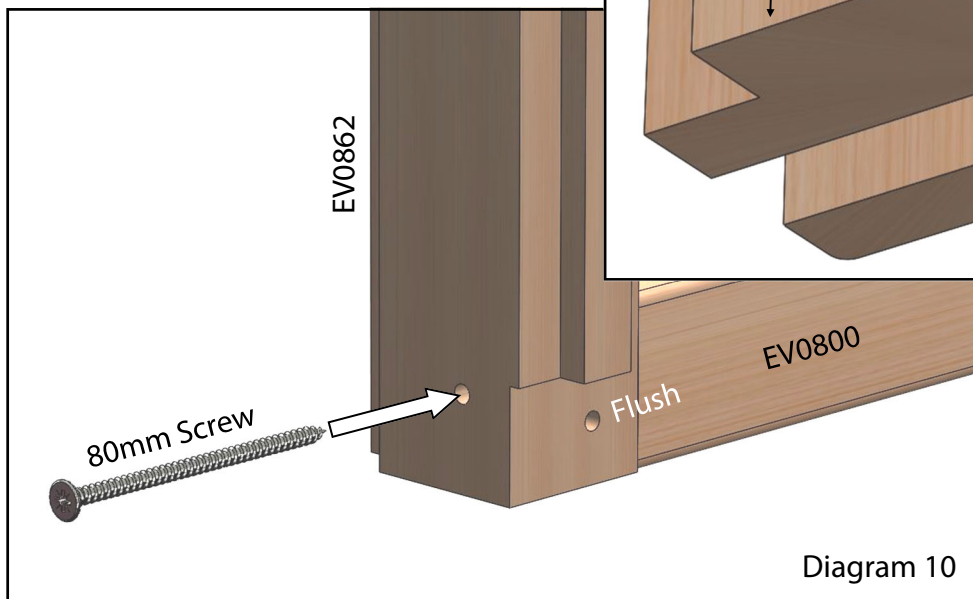
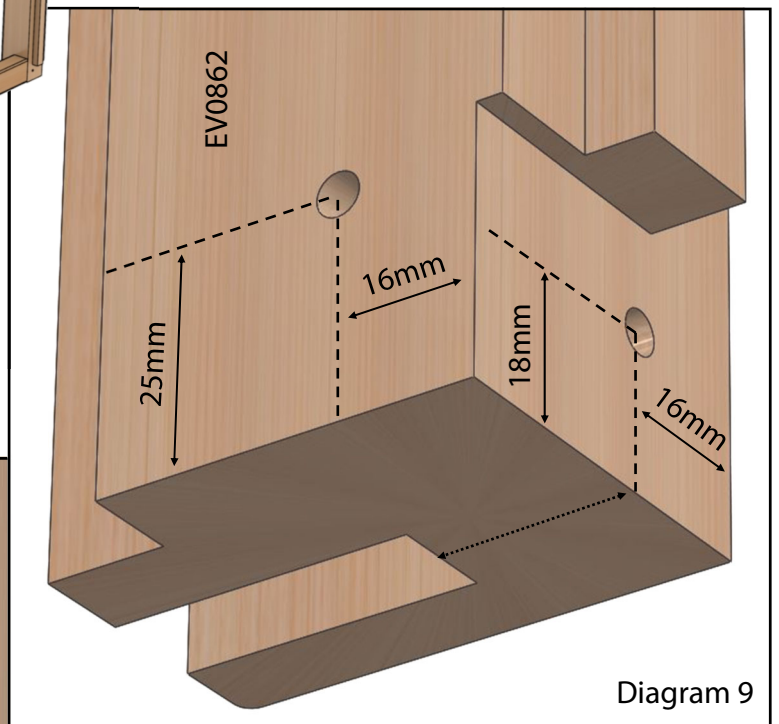
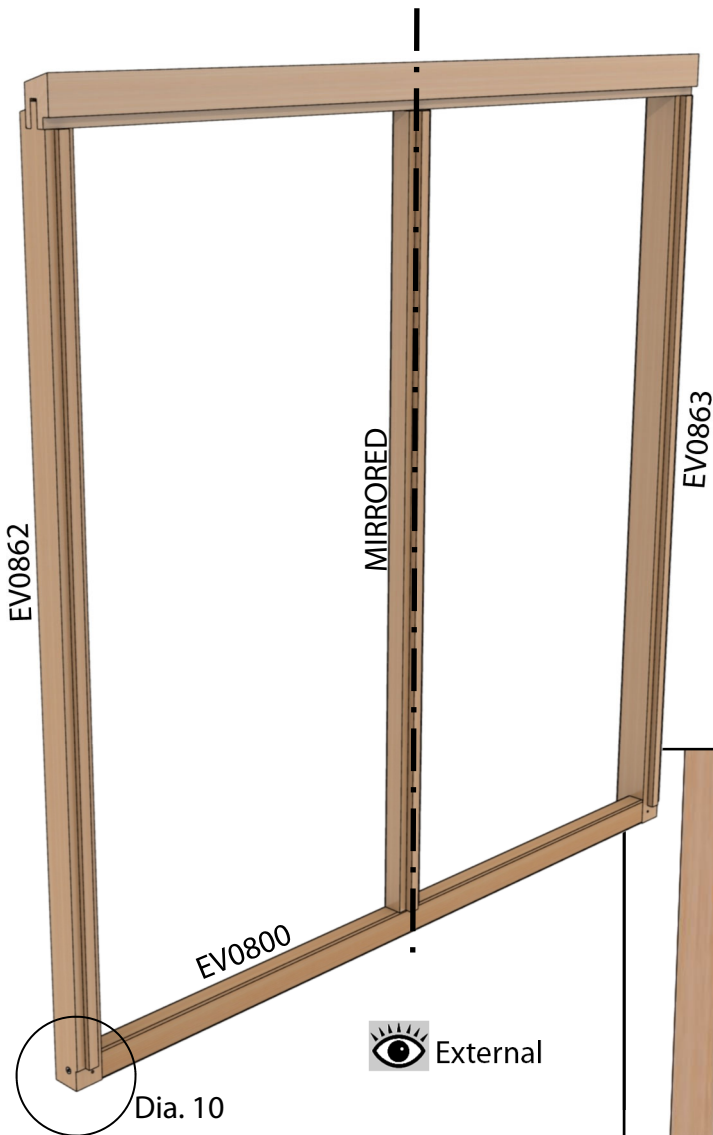

# Rear Assembly

Now fix the top of the rear corners to the top rail with 80mm screws as shown below.

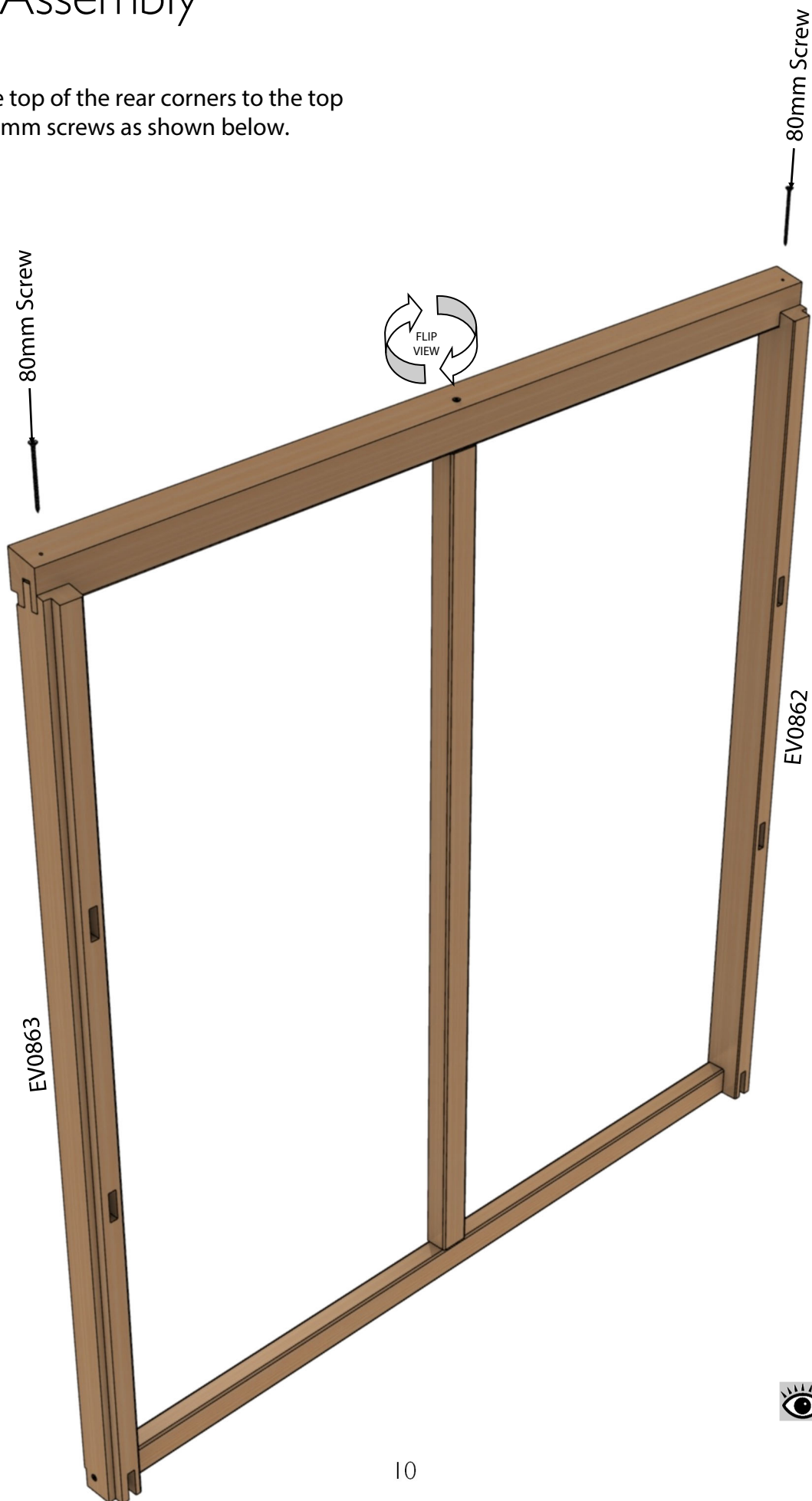

# Frame Assembly

Now you have the front and rear frames assembled you can fit the six side rails 'EV0803' between them. With the help of someone else to hold things for you take the front frame and two side rails, slot these into the bottom mortise holes and fix with 80mm screws (diagram 11).

The upper rails are not secured with screws. Once the top rails are added on the next page they will be locked into place. Push all four of the remaining rails into the front assembly and with help feed their rear tenons into the rear assembly. The bottom rails can now be secured with two more 80mm screws.

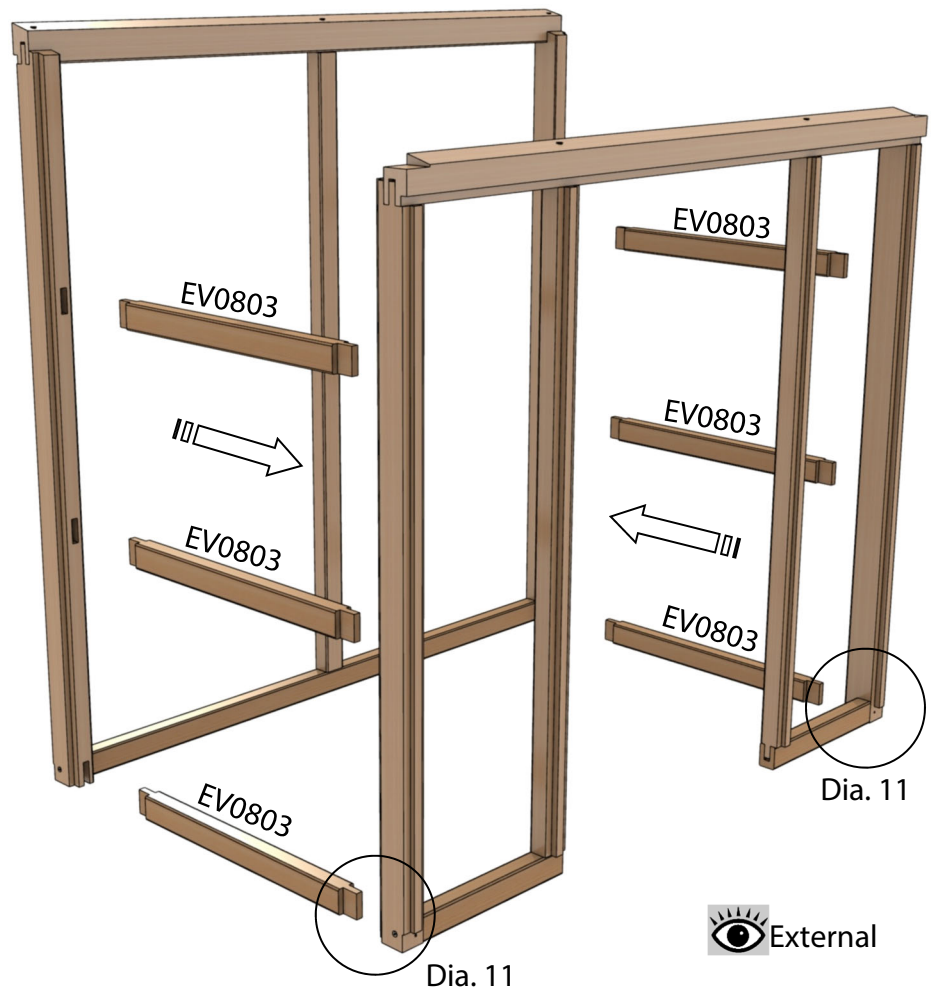

Do not leave the frame unattended until the top rails have been added to make it stable on the next page.

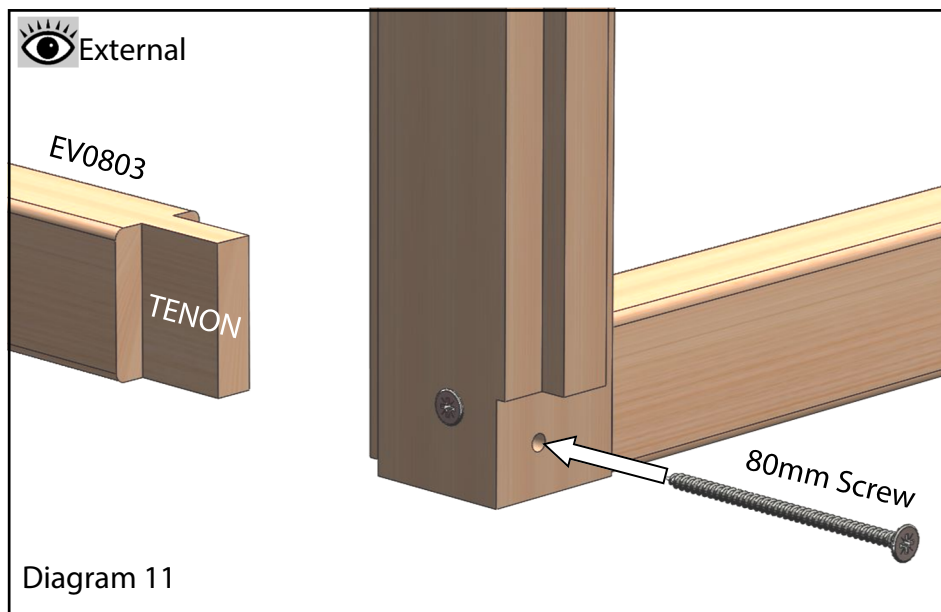

# Frame Assembly

Next you need to fit the top side rails, 'EV0811 / EV0813'. You should slot these into place and drill pilot holes in situ. Diagrams 12 and 13 show the position of the holes along the bars, make sure you drill down vertically so you screw into the correct section of timber below. The holes should be in the centre of the top side rails.

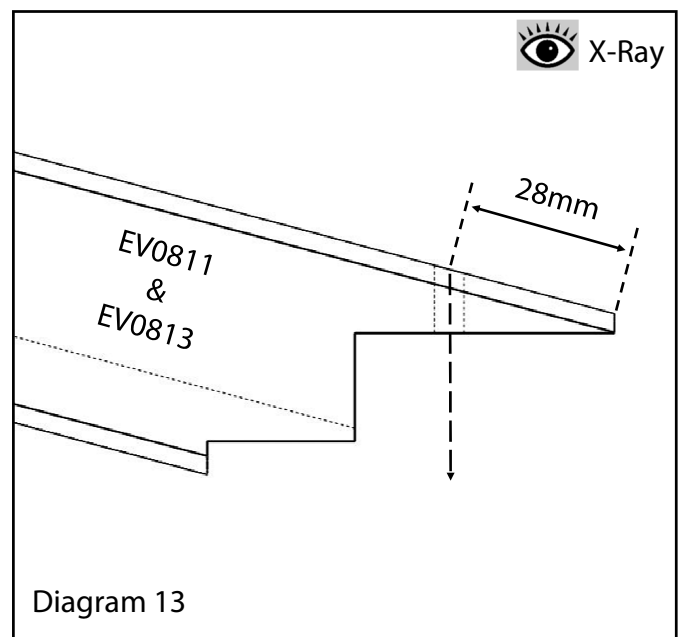
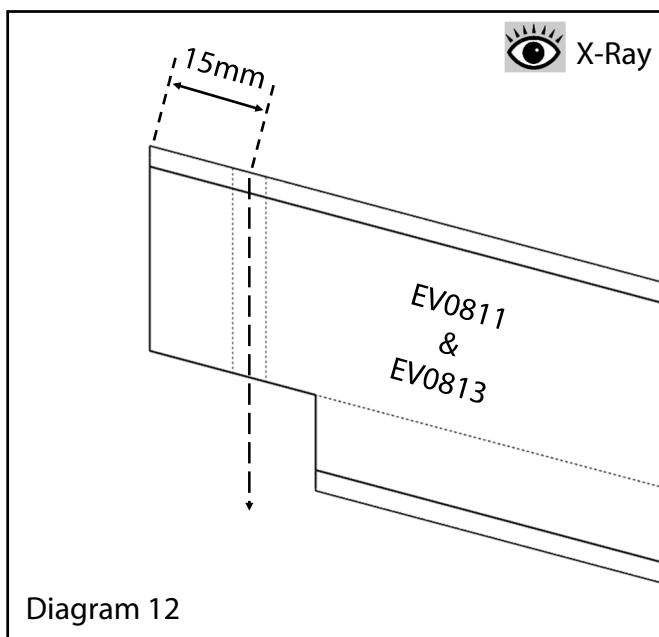
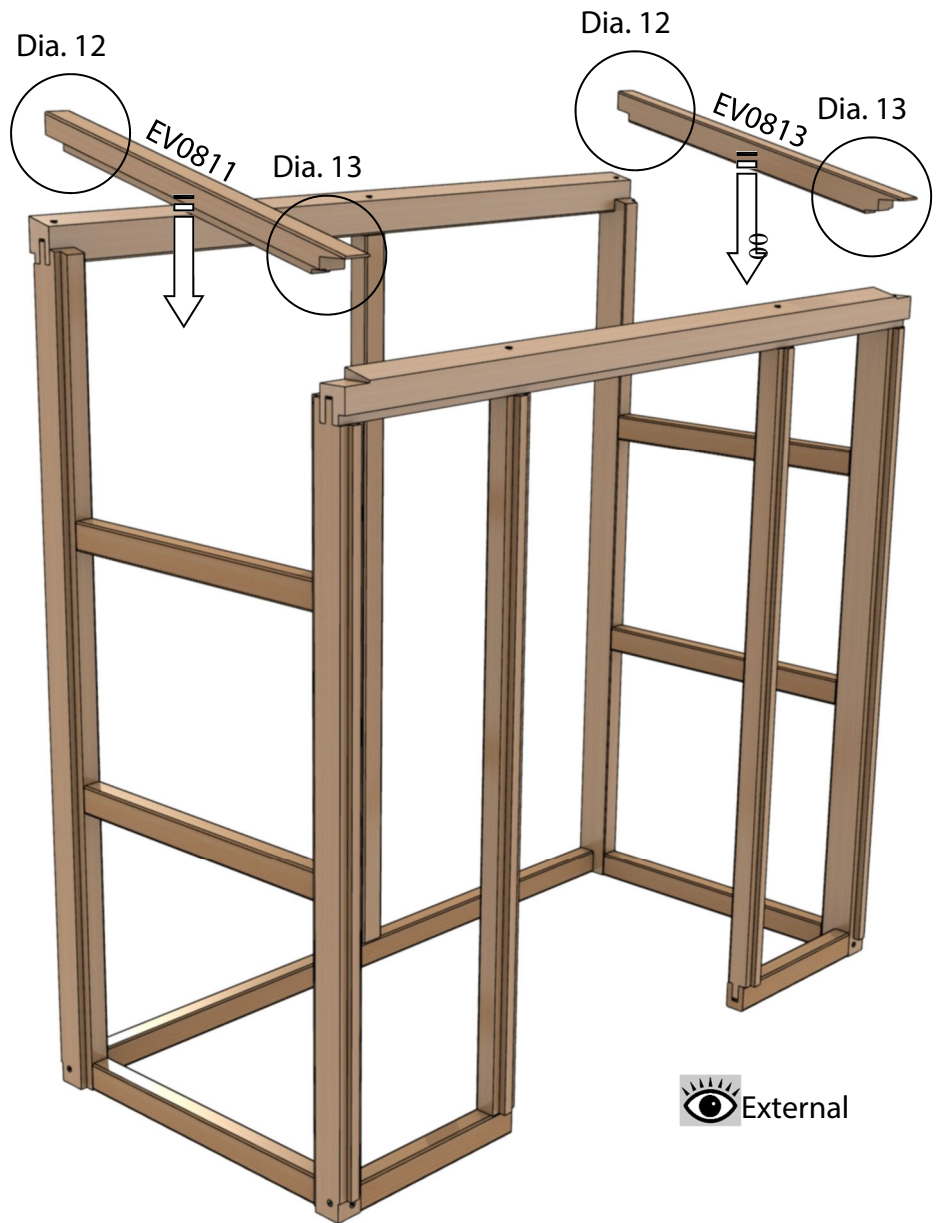

# Frame Assembly

Dia. 14

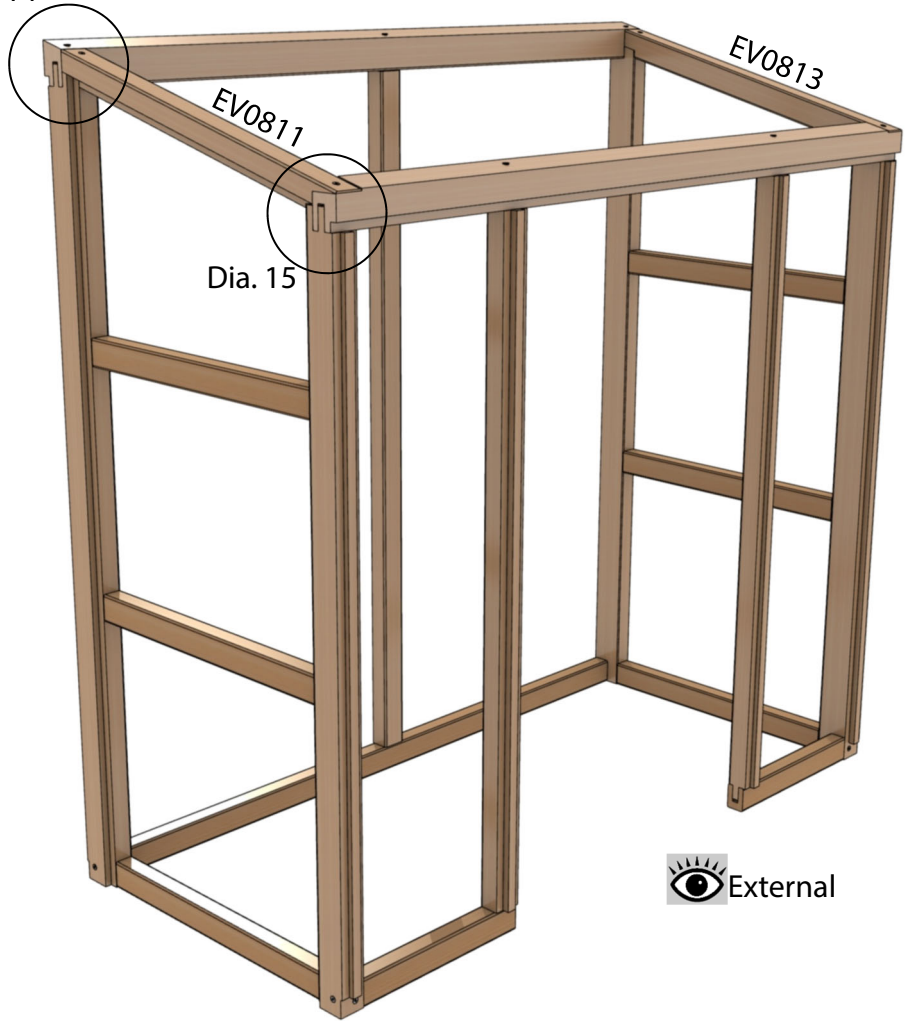

Now the pilot holes are drilled you can fix the top side rails 'EV0811 / EV0813' with 50mm *countersunk* screws at the top (diagram 14) and 80mm *countersunk* screws at the bottom (diagram 15).

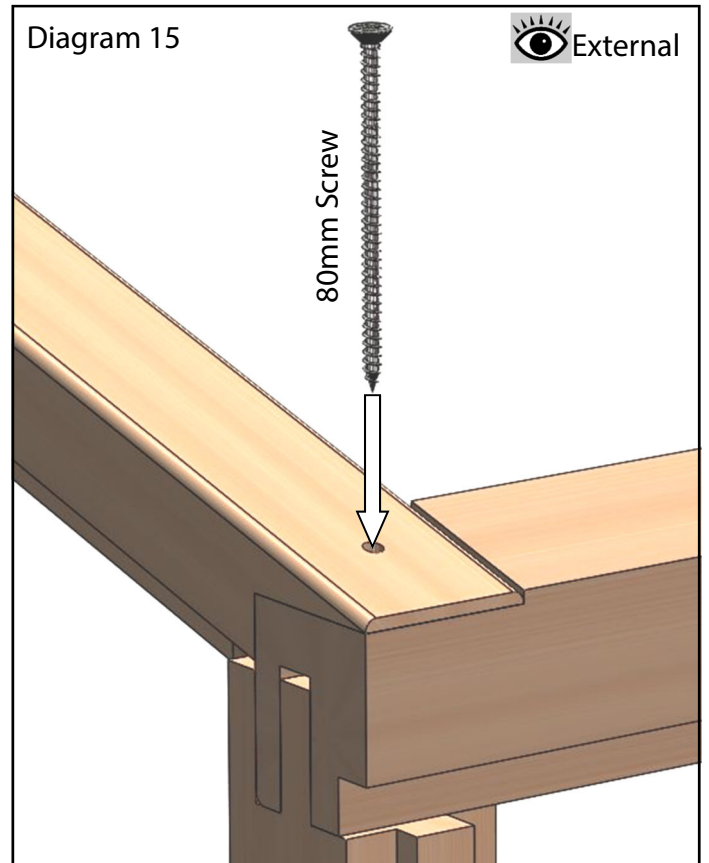
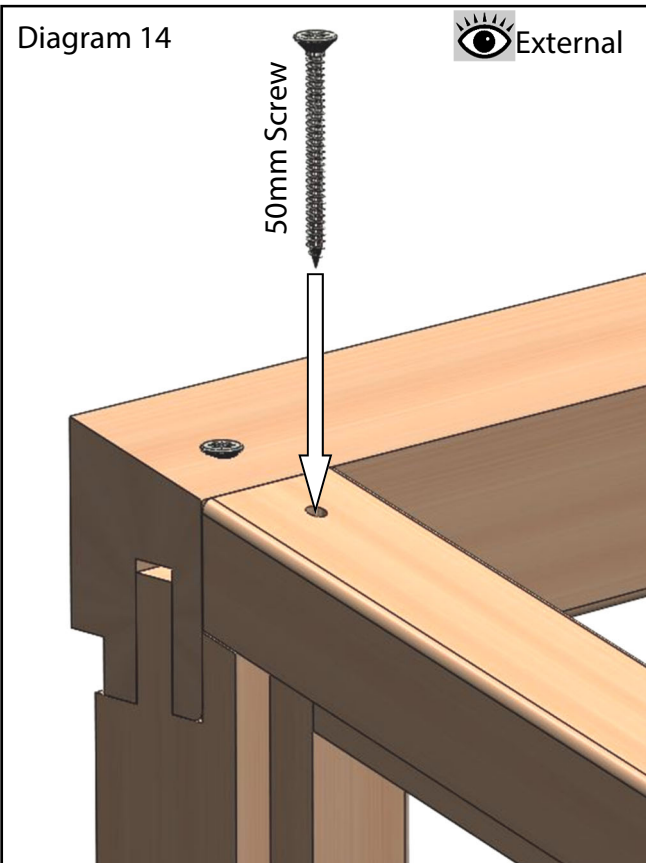



# Base Assembly

Now the wooden frame is complete you can move that to one side and assemble the aluminium base plinth. Lay them out as shown below.

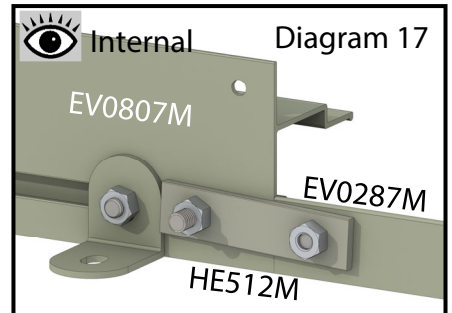
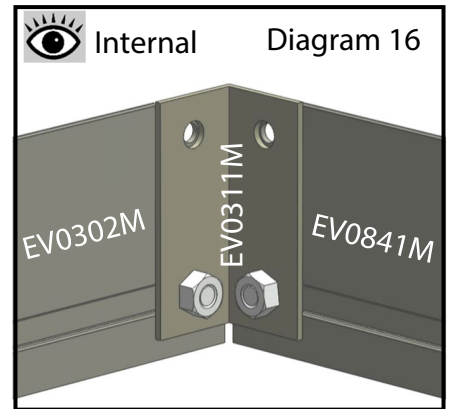
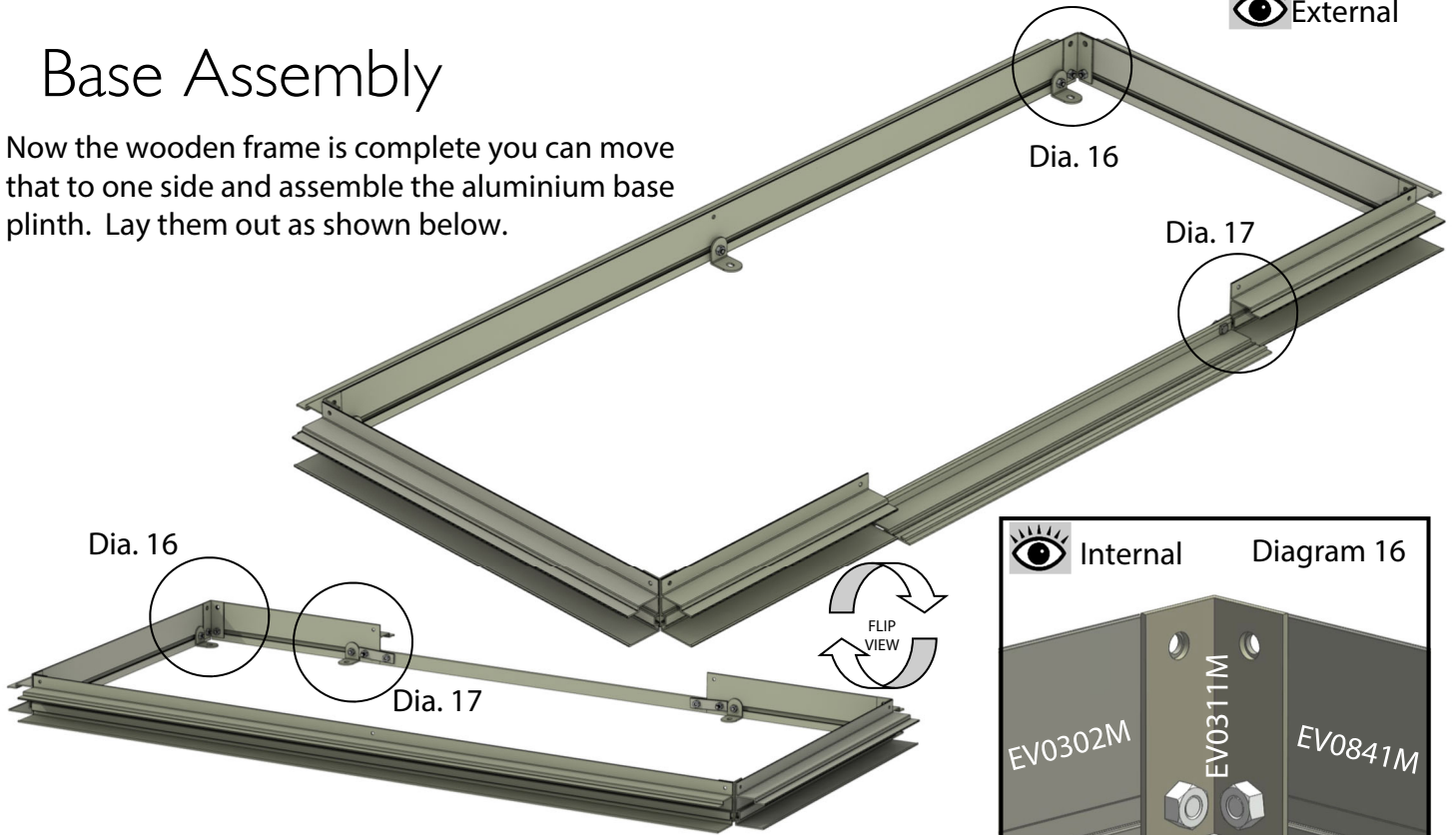

Use the four corner brackets (EV0311M) with the M6 nuts and square headed bolts supplied to join the base sections together, diagram 16. The square bolt heads slide into the bolt channel in the base extrusion. For now just fit the nuts finger tight. You will find seven small 'L' shaped brackets 'D174M' with the smalls pack, attach these to the base with the crop head (rectangular twist-in) bolts, locations shown below).

The door cill 'EV0287M' is mounted between your front base sections 'EV0807M' using two 'HE512M' flat plates and four square headed M6 bolts and nuts, diagram 17.

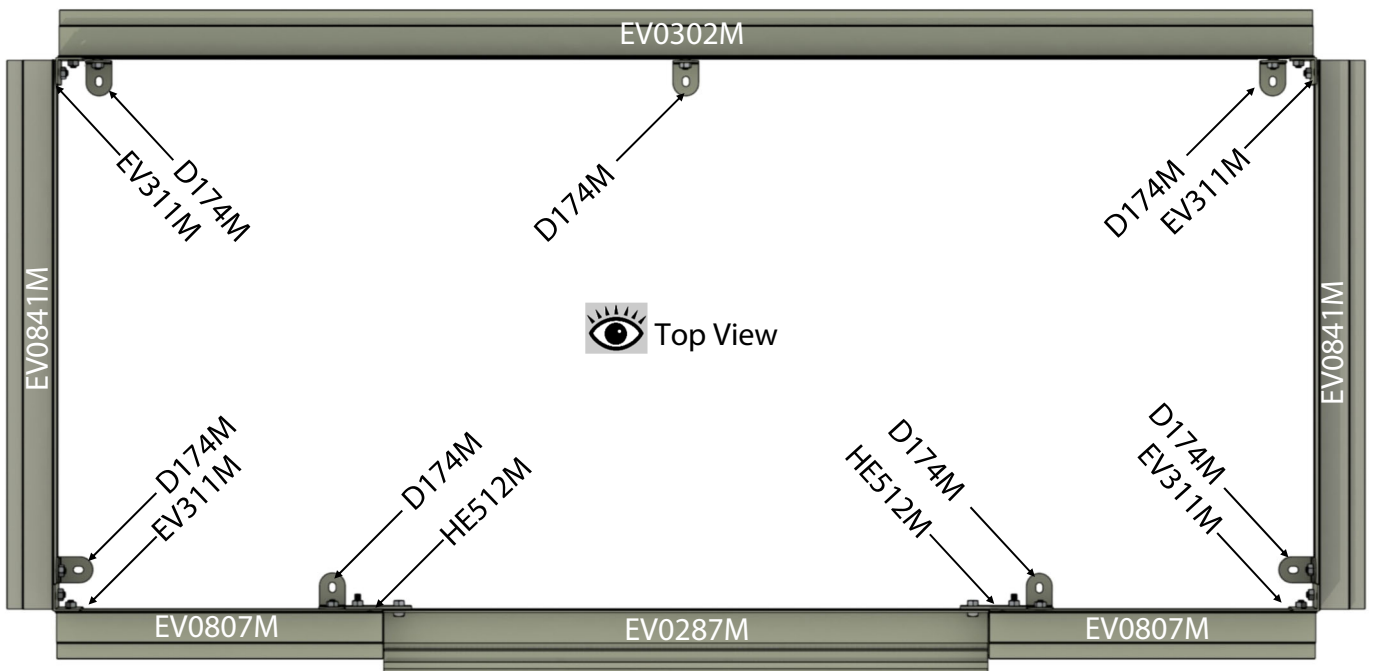

## Base Assembly

Now with help lower the assembled wooden frame onto the aluminium base plinth, you may find you need to adjust some of the corner brackets to allow the frame to slot onto the base. Once fitting well tighten the nuts on your base.

Use 25mm Pan Head screws to fix the aluminium base to the frame, diagram 18. These should go in all of the pre-drilled holes including the top holes of the corner brackets.

You are now ready to start glazing which should all be done in one go to avoid the chances of the frame being blown over by the wind.

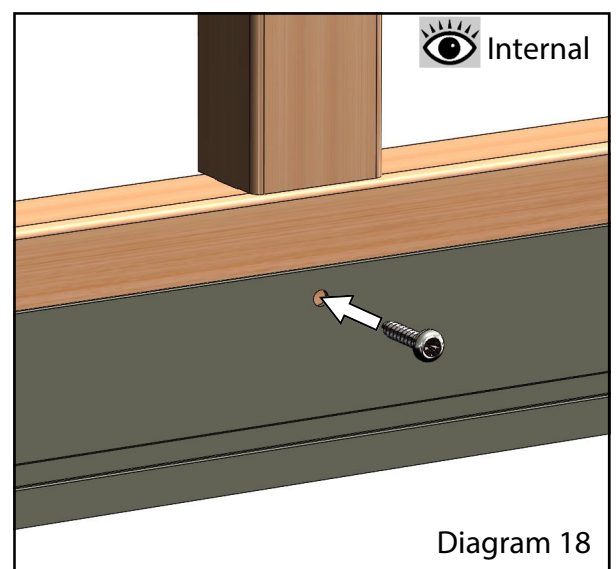
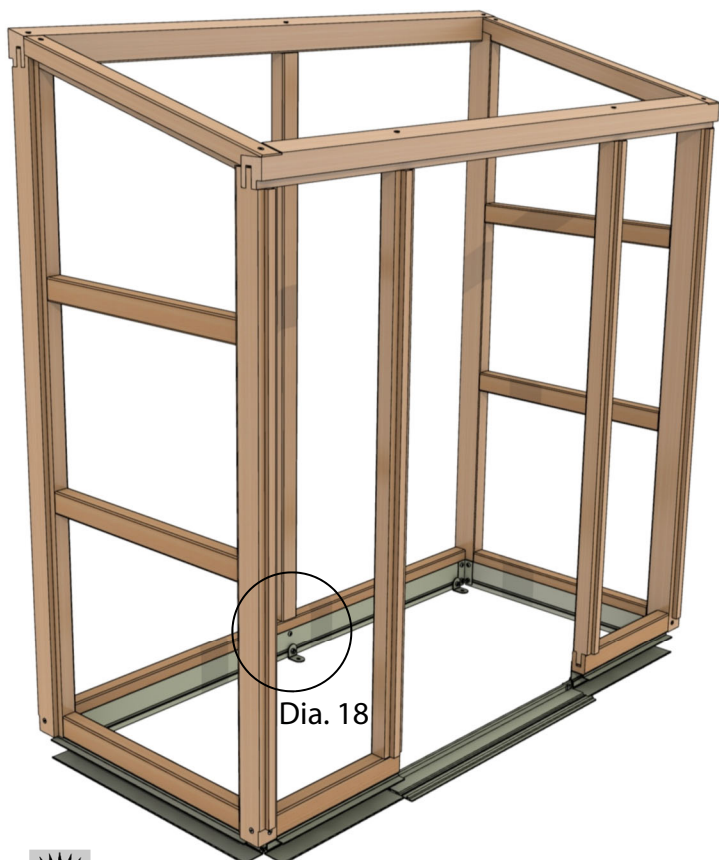
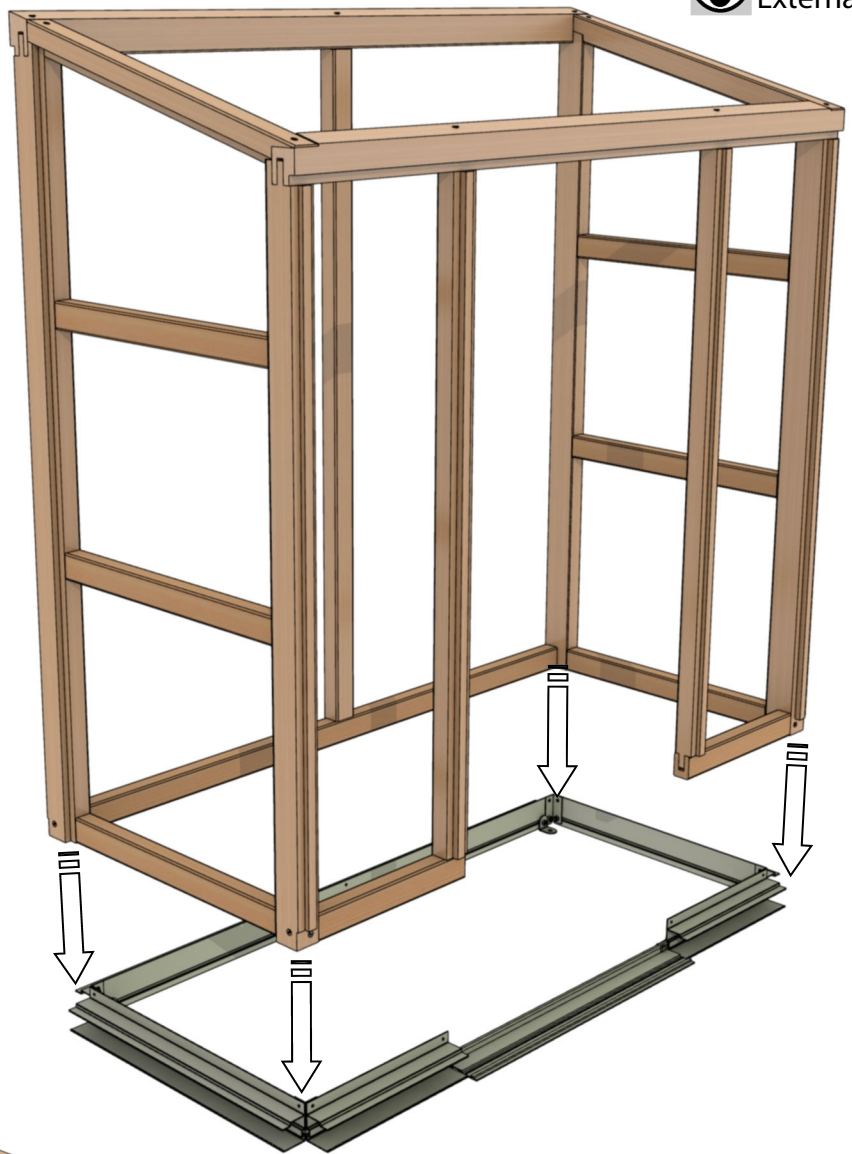

# Glazing

Description:	Alton Evolution Tall Cold Frame 2ft x 4ft Glass List	
Product Code	Description	Quantity
<b>298x1118</b>	TG 298 x 1118	2
<b>EV509x1277x1141</b>	TG 509 x 1277 x 1141 Trapezium	2
<b>610x610</b>	TG 610x610	2
<b>243x1009 (fitted)</b>	TG 243x1009 Door Pane	2

Insert the left trapezium shaped side pane and fix the side cloaking board 'EV0826' with three 40mm Pan Head screws to hold it in place. Line this up with the top edge and the front face of the front top rail. Now fit the left end capping strips 'EV0839' and 'EV0850', push these tight up against the underside of the cloaking board and fix each with three 25mm Pan Head screws.

Continue working around the cold frame by glazing the front. Insert the front panes with someone else to assist and then fix the front cloaking board 'EV0827' with four 50mm *countersunk* screws. The board should sit flush with the top face of the front rail, see diagram 19. Now fit the front capping strips 'EV0843', push these tight up against the underside of the cloaking board and fix each with three 25mm Pan Head screws.

Leave fitting the right trapezium until later in the assembly so you can feed in the internal shelves in from that end later.

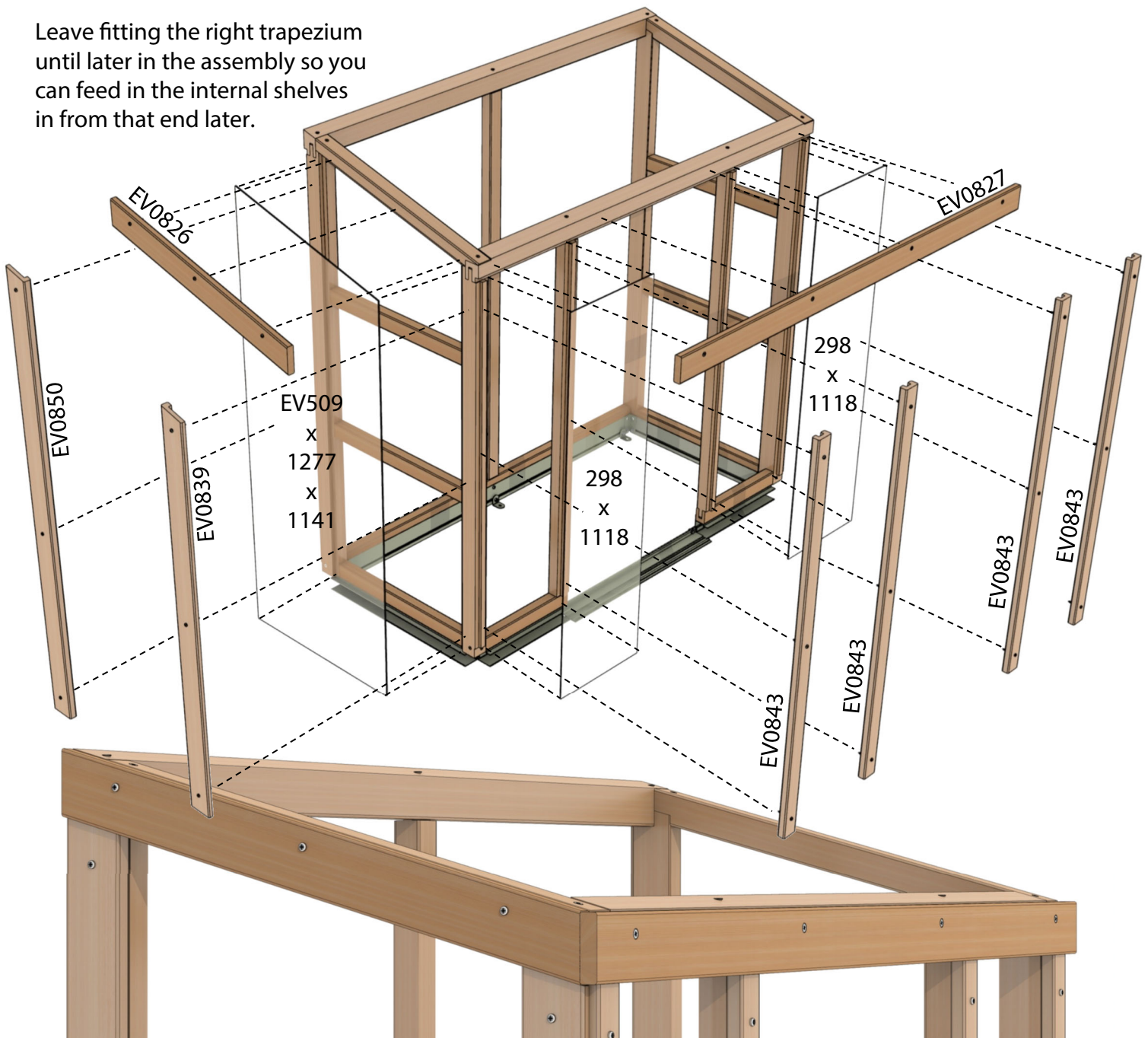

Diagram 19

# Doors Installation

Before installing the doors you need to fit the running gear. Start by assembling the door wheels onto the door top brackets 'EV0317M', diagram 20. Be careful to orientate the wheels to match the picture. Once assembled fit the brackets to the top of the doors using 25mm pan head screws.

Now fit the door handles with 25mm pan head screws, diagram 21.

Trim your plastic 'D225' door glides to match the length of your 'EV0319M's' and then push them together, see diagram 22. Now fix to the bottom of each door with four 25mm pan head screws. Keep the down leg of the 'EV0319M' in line with the inside edge of the doors, diagram 22.

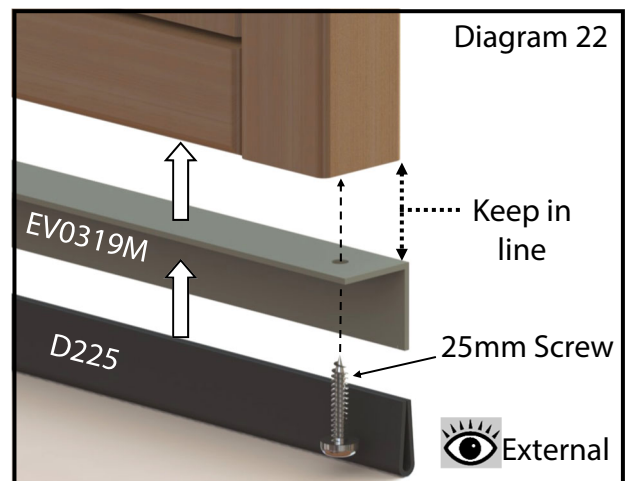
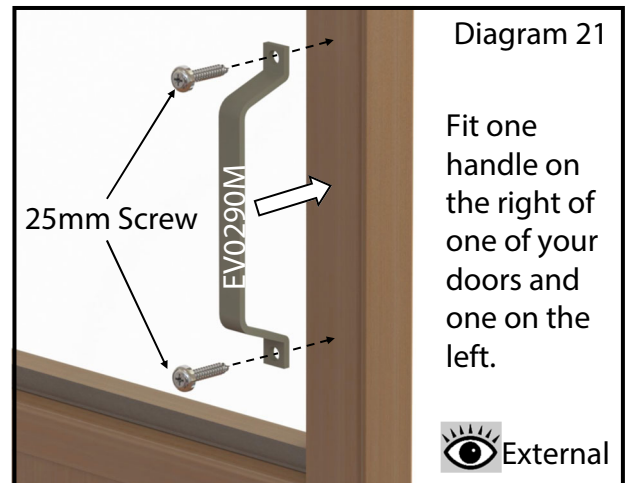
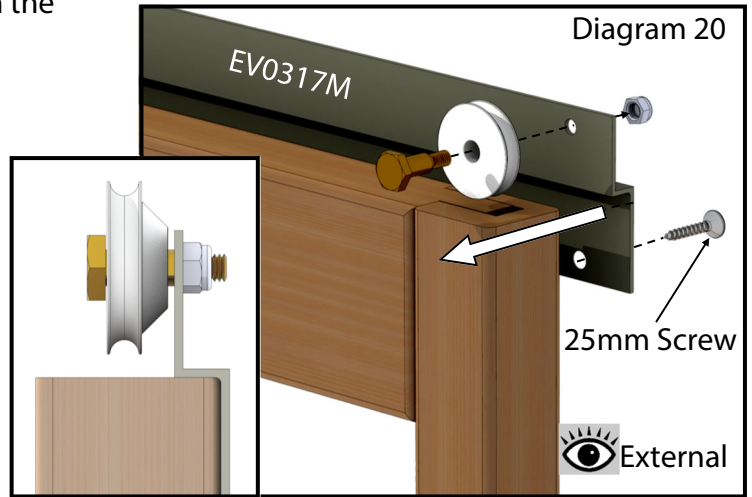
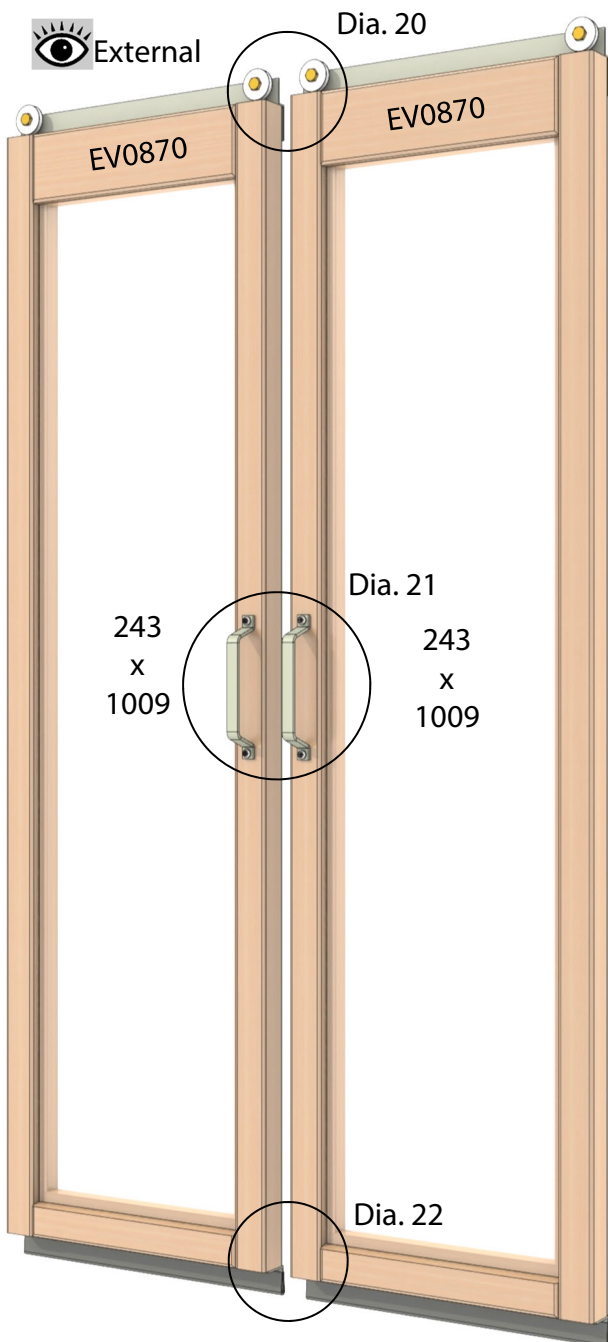

# Doors Installation

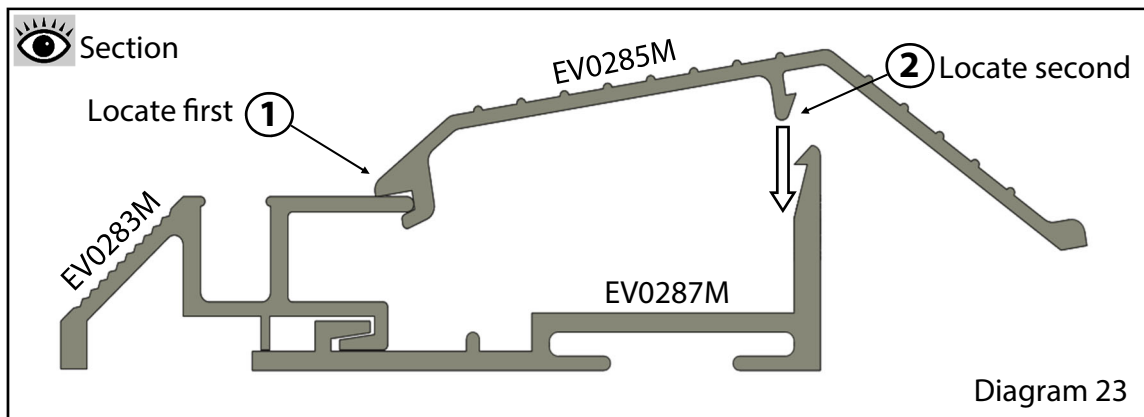

Next install the bottom door guide (EV0283M) onto the door cill (EV0287M) shown in diagram 23. Make sure the channels are free from grit and that this locates properly as you may find the next stage difficult if this is not the case. Now fit the threshold section (EV0285M) in the middle of the door way. Locate the bottom edge of the threshold on the top lip of the door runner (point 1) and force the threshold down until it locks into place (point 2). You may find it easier to stand on this and walk along it or if you have a rubber mallet this is also a good tool for the job.

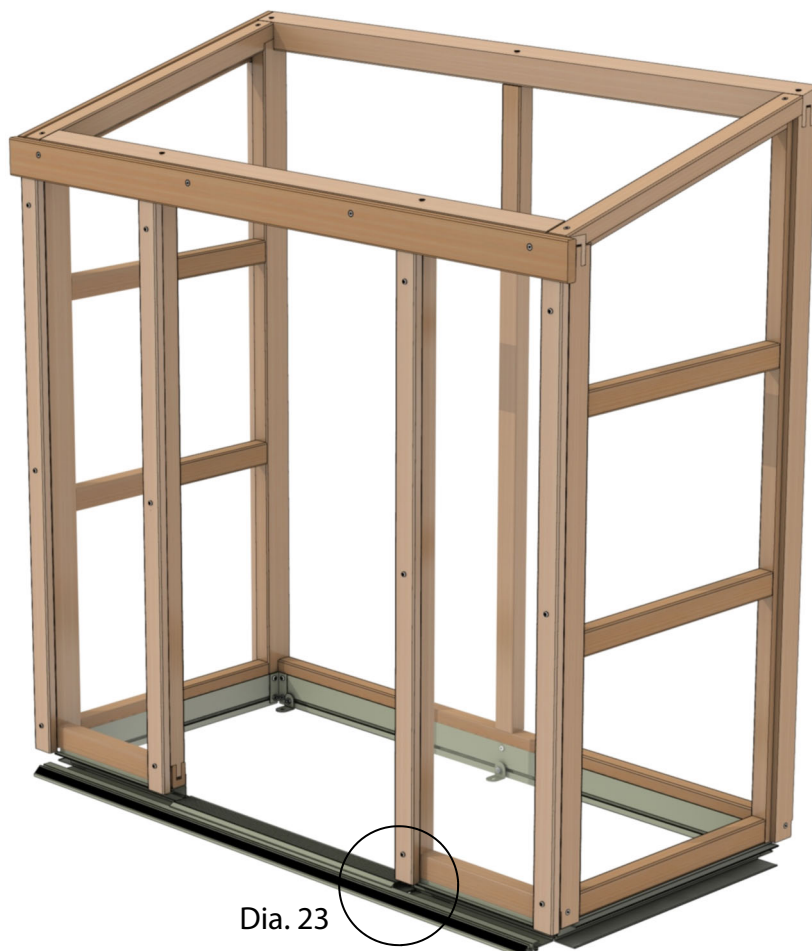

# Doors Installation.

You can now fit the top door track 'EV0280M' to your building, central to the front 'EV0827' cloaking board. With help slide the left hand door onto the track from the left hand end making sure the door wheels locate with the door track as shown in diagram 25, point 4. At the same time you need to locate the door guide within the 'EV0283M' door runner, point 5.

Holding the door up by a few mm's so that it is just located in the runner (diagram 42, point 5) fix the track with the first 25mm pan headed screw at point 1 in diagram 24. The top edge of the door track should be close to the top edge of the cloaking board.

Next slide the right hand door onto the track, again adjust the position of the track until you are happy with its location and level and fix with a 25mm screws at points 2 and 3.

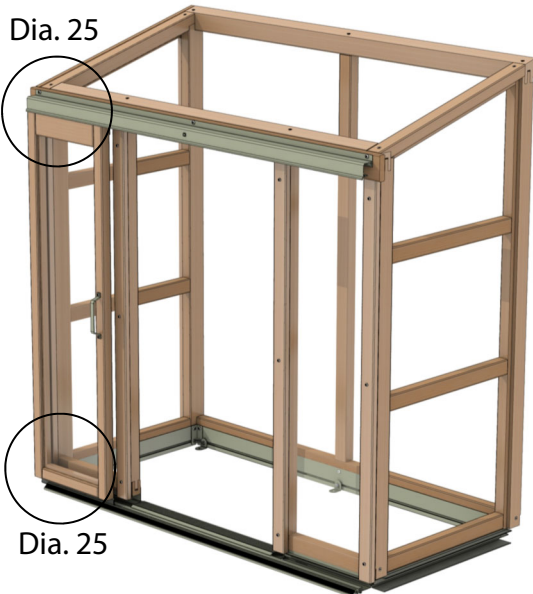

Diagram 24

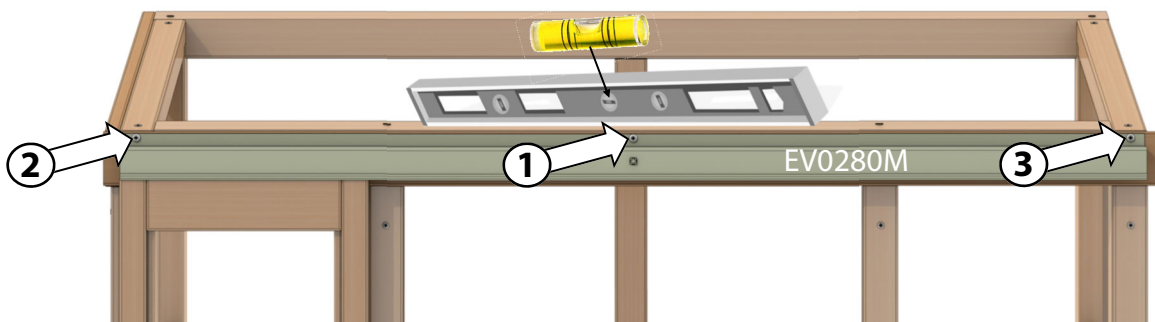
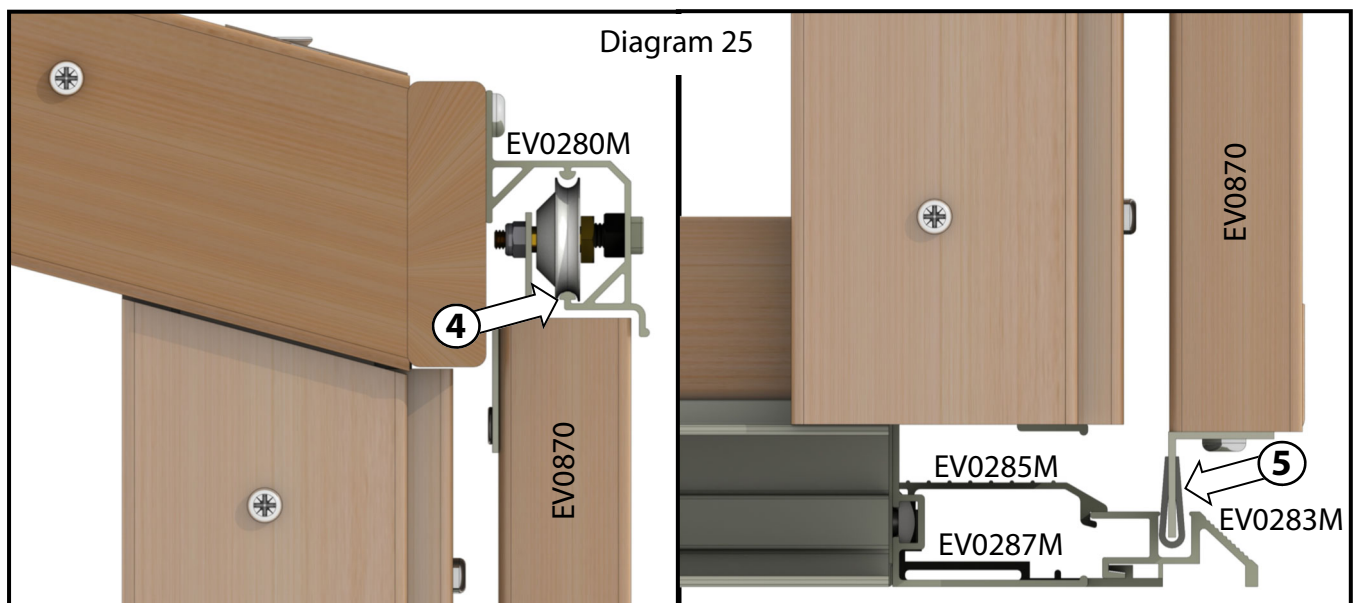

Diagram 25



# Doors Installation.

Accessing the inside from the rear with the doors in the closed position you can now install the door frame sides 'EV0857', see below. Pilot hole and fix these both with three 40mm pan screws per side. These should be fitted as close to the door as possible while still allowing it to pass by freely.



 External

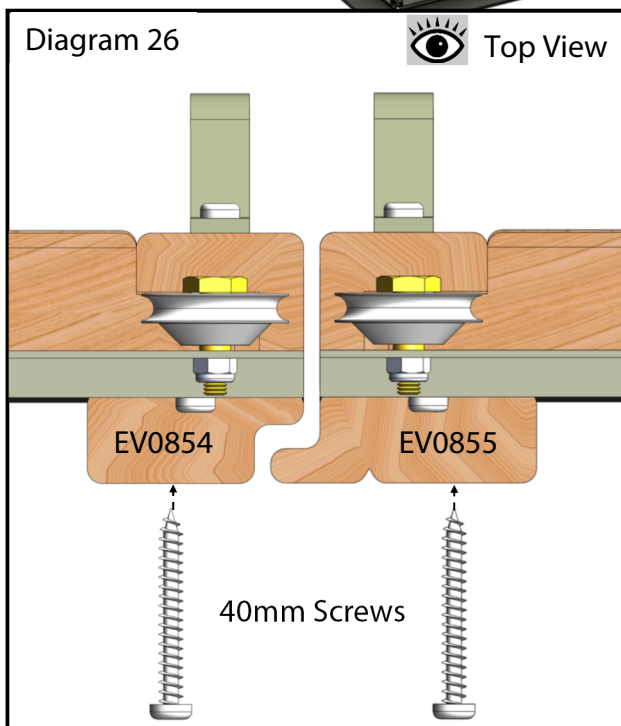

You can now install the rebate strips 'EV0854 / 855' to the inside of your doors, see above and Diagram 26. Pilot hole the strips first. It is best to do this away from the greenhouse with the 2 strips pinched together so you get the holes in the same positions. Drill 3 holes equally spaced then fix these with 40mm screws.



# Rear Panels

The preassembled rear panels 'EV0873' can now be added and retained by the horizontal rear clocking board 'EV0827' using four 40mm pan head screws, diagram 27. The top face of the EV0827 should be flush with the top rear edge of your cold frame ridge, 'EV0808'.

Three verticals trims 'EV0842 / EV0846' can then be butted up to the underside of 'EV0827' shown below using nine 40mm pan head screws.

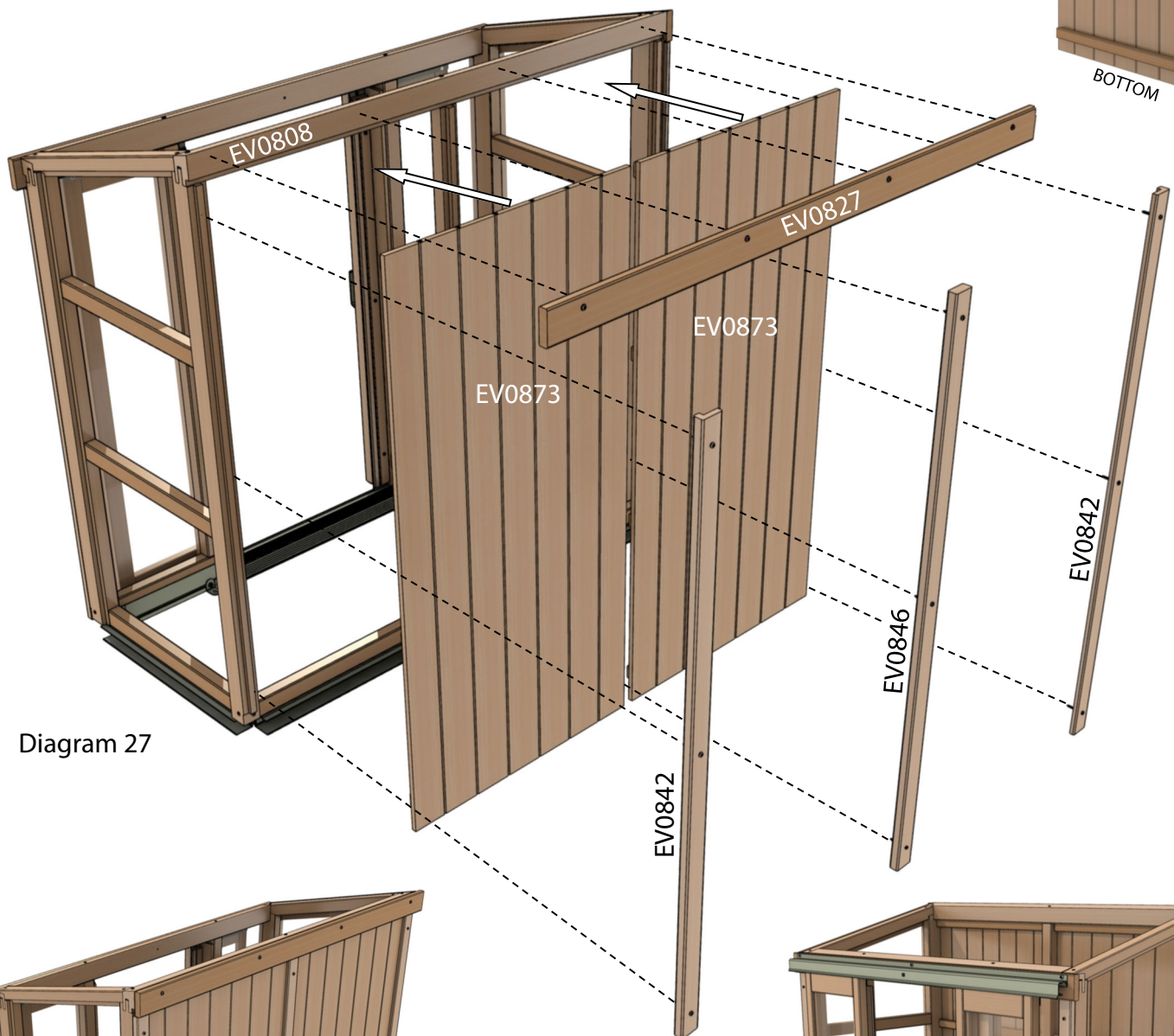
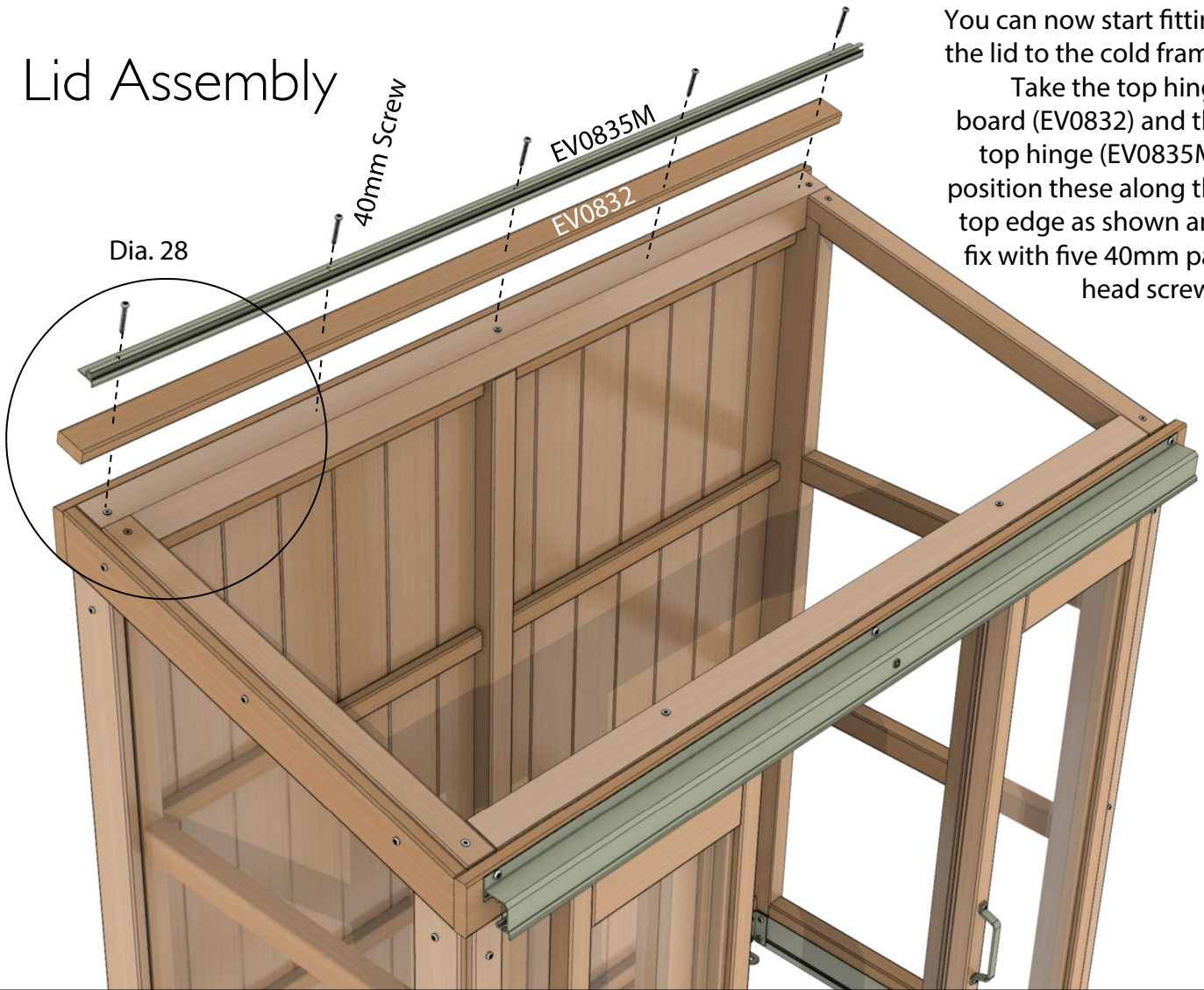

Diagram 27



# Lid Assembly



You can now start fitting the lid to the cold frame.  
Take the top hinge board (EV0832) and the top hinge (EV0835M), position these along the top edge as shown and fix with five 40mm pan head screws.

Diagram 28



# Lid Assembly

If you want to fit the manual lid support 'EV0856' to the frame you can do that now. The alternative is to leave this off and fit an autovent instead, see **page 29**. You can not fit both options at the same time.

Use a 50mm *countersunk* screw and 2 x M6 washers.  
Screw through the pre-drilled hole in the support into to the inside face of the front top rail. Refer to diagram 29 below for the position.

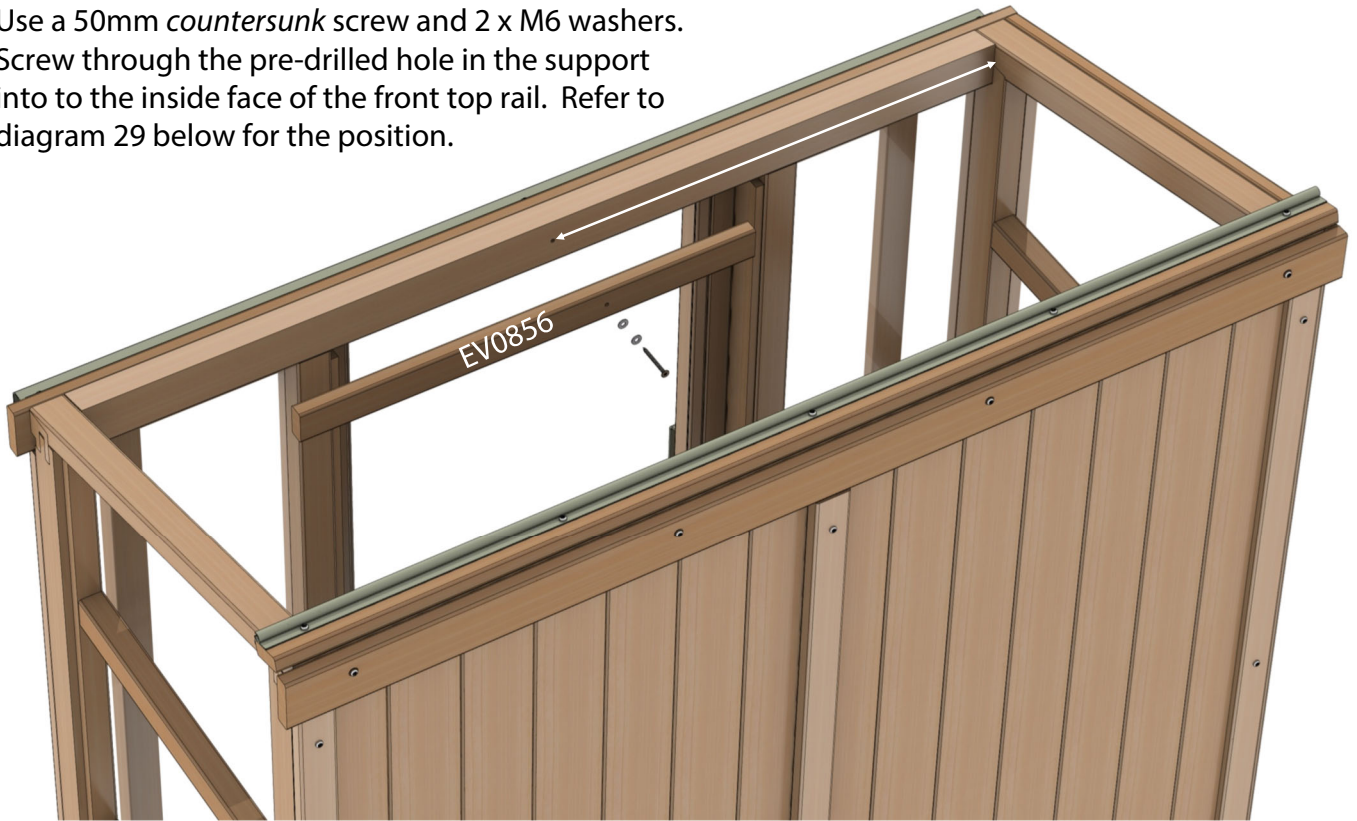
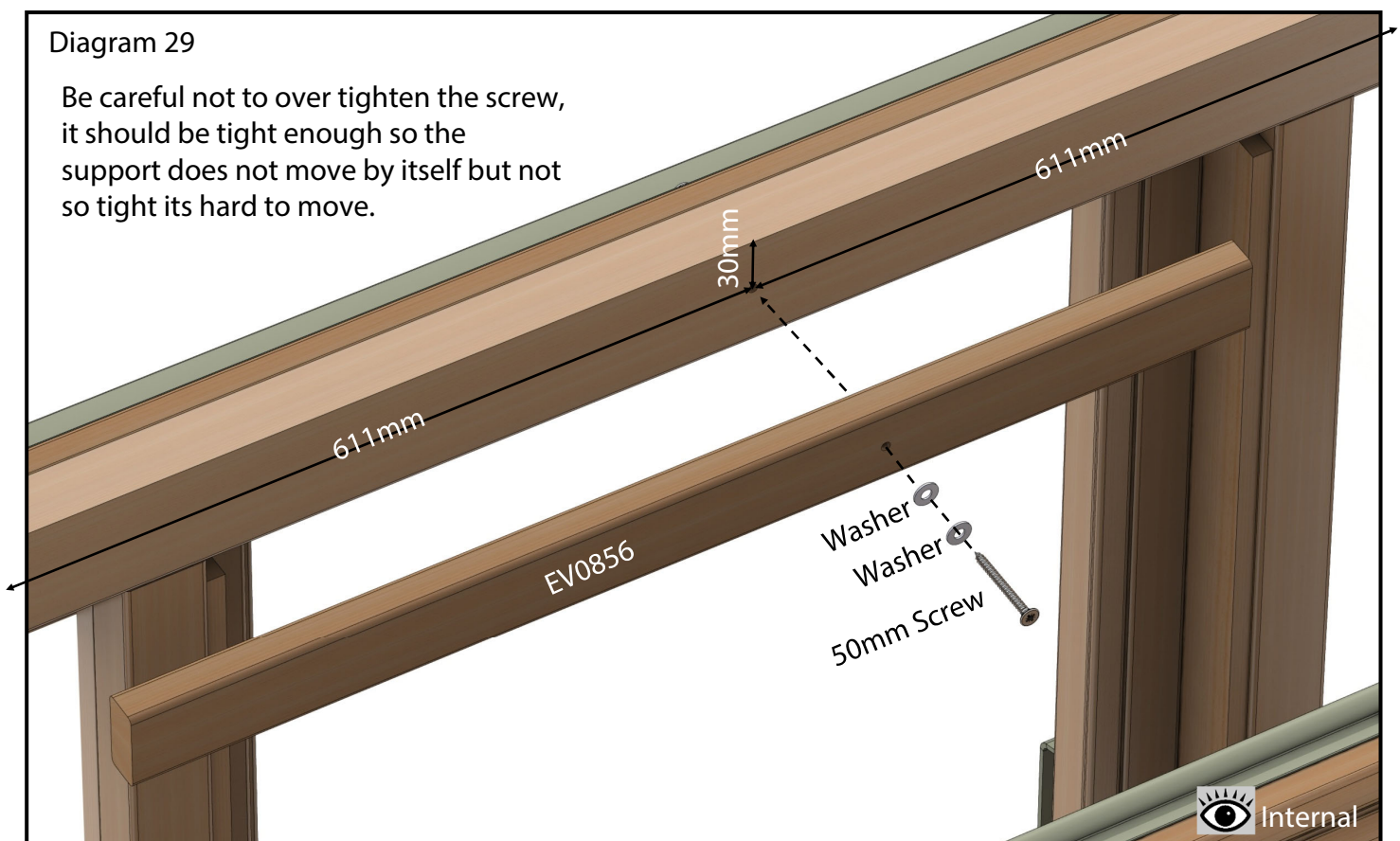

Diagram 29

Be careful not to over tighten the screw, it should be tight enough so the support does not move by itself but not so tight its hard to move.



## Lid Assembly



Check the tightness of the screw allows the prop to move without too much effort.

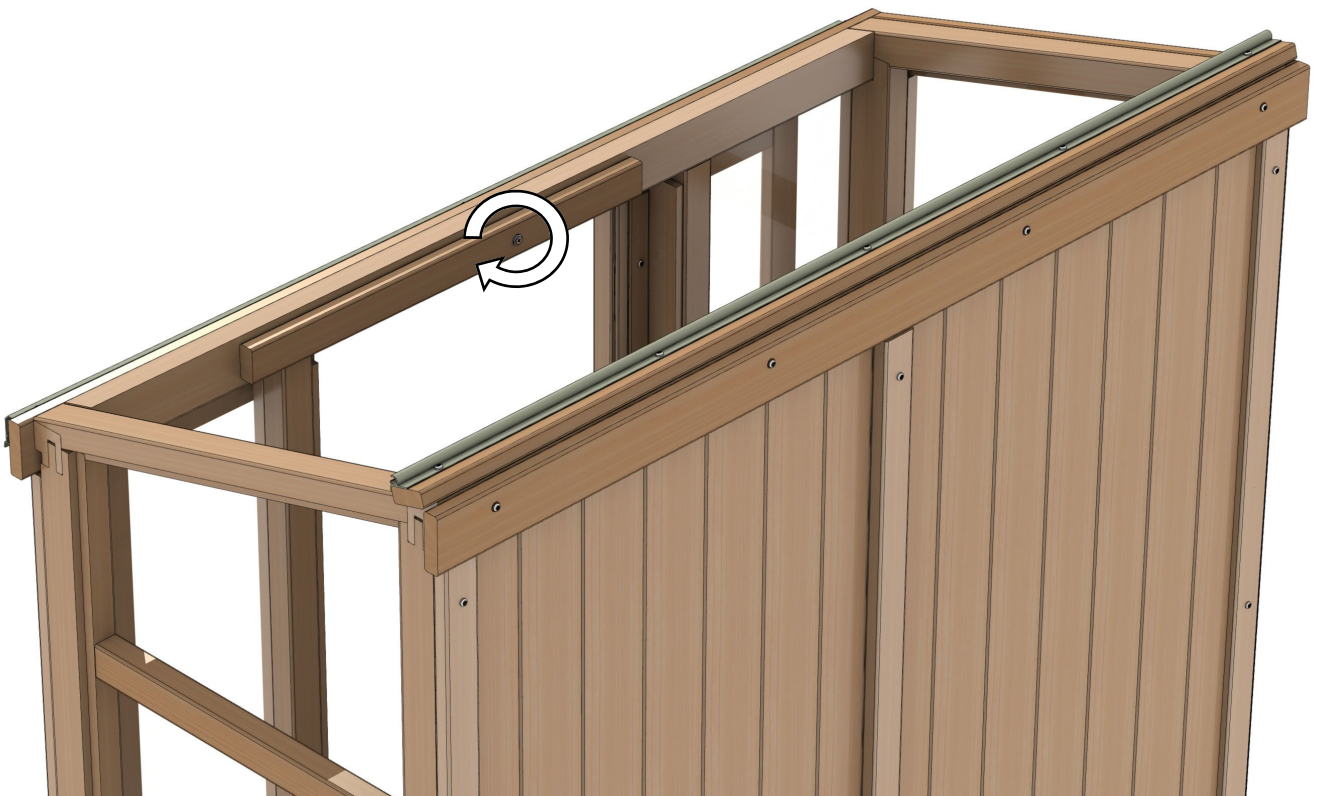

# Lid Assembly

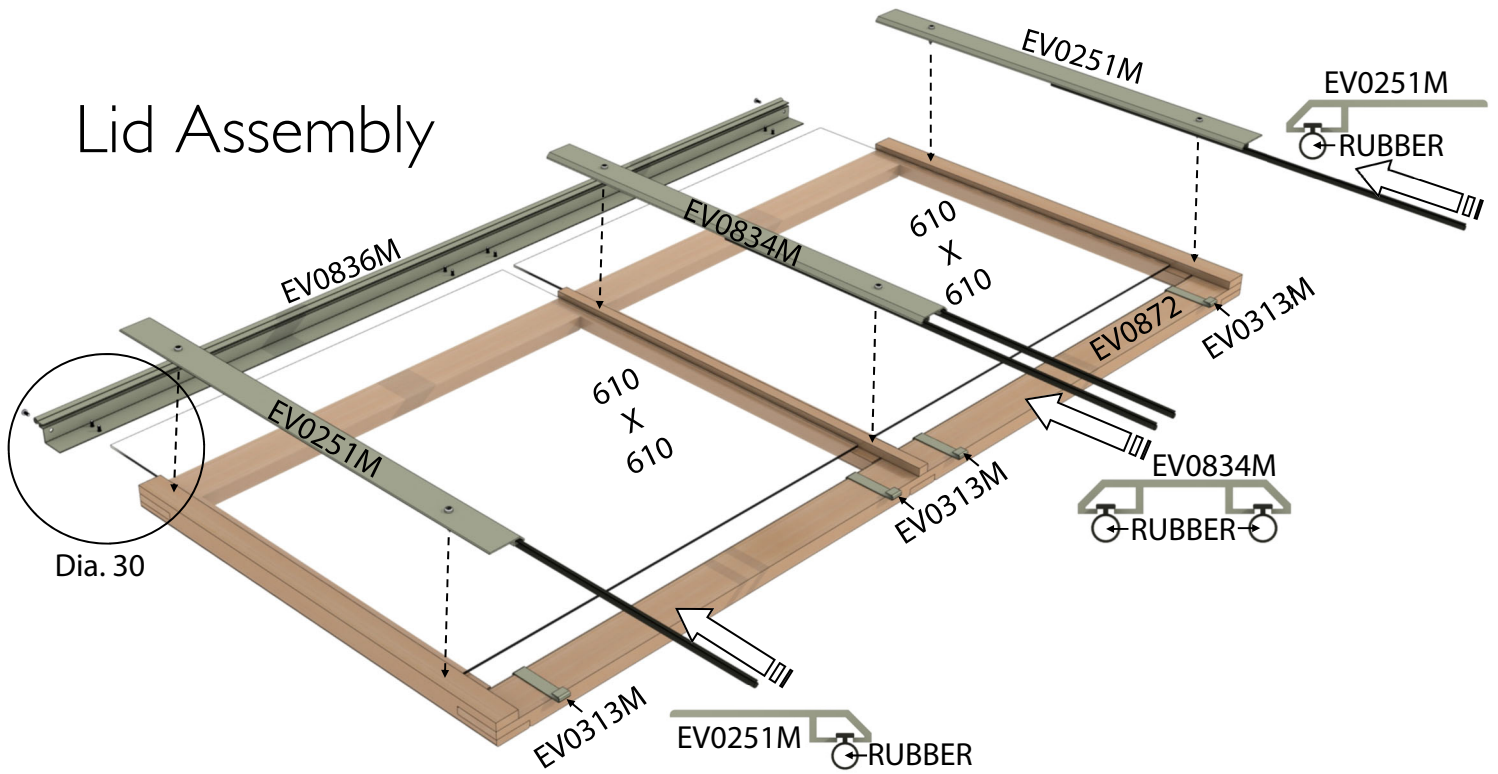

Take the wooden double vent frame that is ready assembled 'EV0872' and fix the vent hinge 'EV0836M' through the ten pre drilled holes using 19mm pan head screws, diagram 30, three at each end and four in the middle. Make a pilot hole before fixing the 19mm screw in the back of the vent to prevent it splitting.

Now take the 610mm x 610mm panes of glass and locate them in the vent hinge slot. Hook two glass stops 'EV0313M' onto the bottom of each pane and then lower the glass onto the frame so the hooks latch onto the vent bottom.

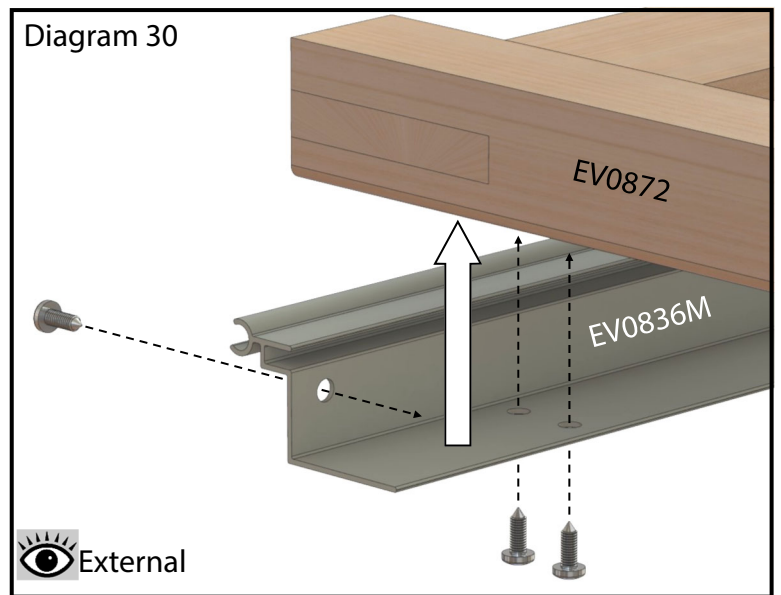

You can now fix the glass in place with the aluminium vent capping using the 25mm pan screws, diagram 31. You will need to insert the rubber seal and cut it to length into each piece of capping (EV0251M or EV0834M) before fixing them in place.

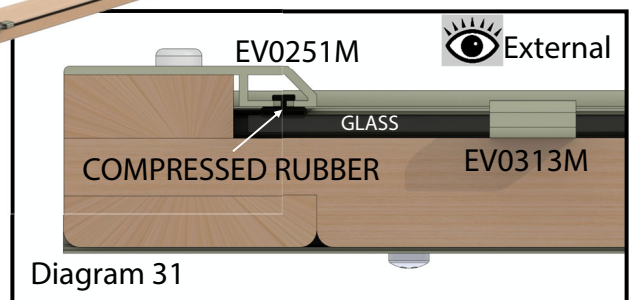
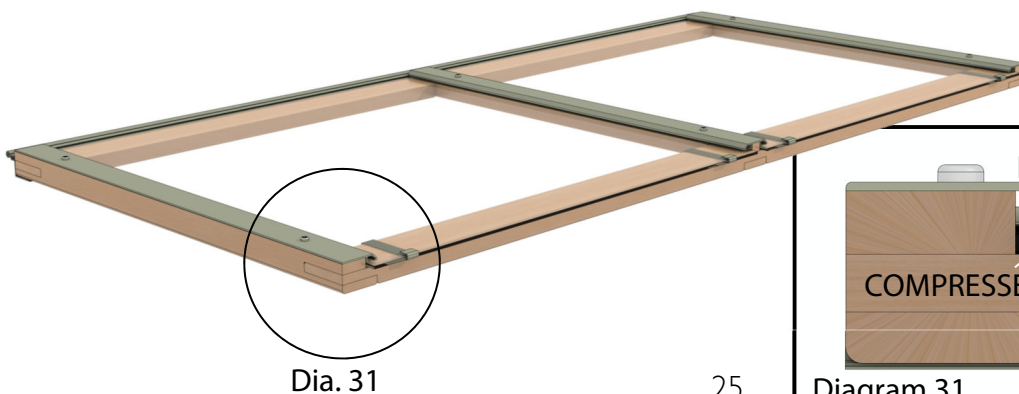

# Lid Assembly

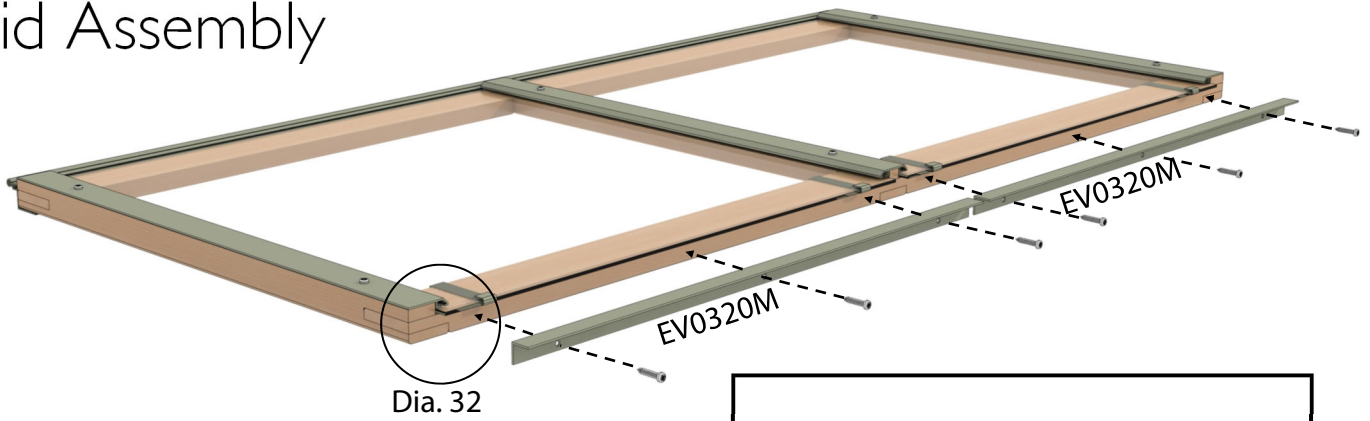

Next fit the EV0320M handles to the lid, use pan 25mm screws to attach this tight under the lip of glass at the bottom of the vent, diagram 32. (These act as a handle but will also protect the front edge of the glass).

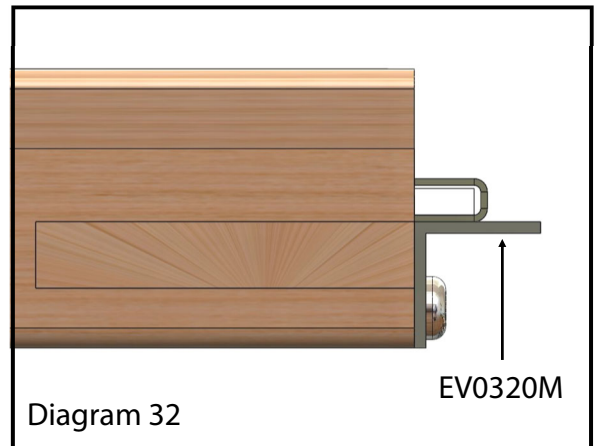

Now the lid is complete you can install it on the cold frame. Slide it along the top hinge 'EV0835M' from one end and lower into position (diagram 33). D220 vent barrels and FS6060 bolts stop the lateral movement of the vent once centralised in position (diagram 34).

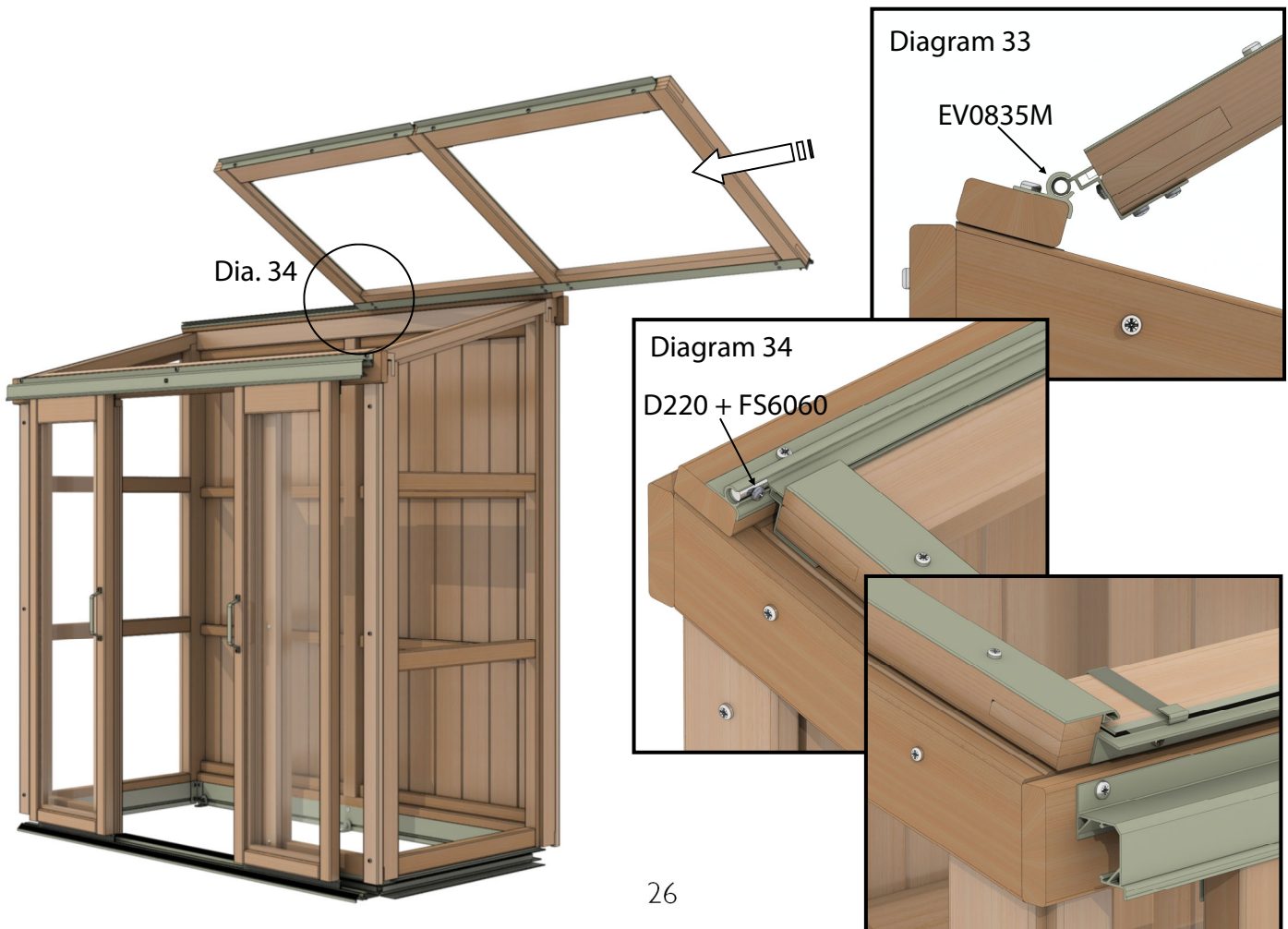

# Anchoring Down

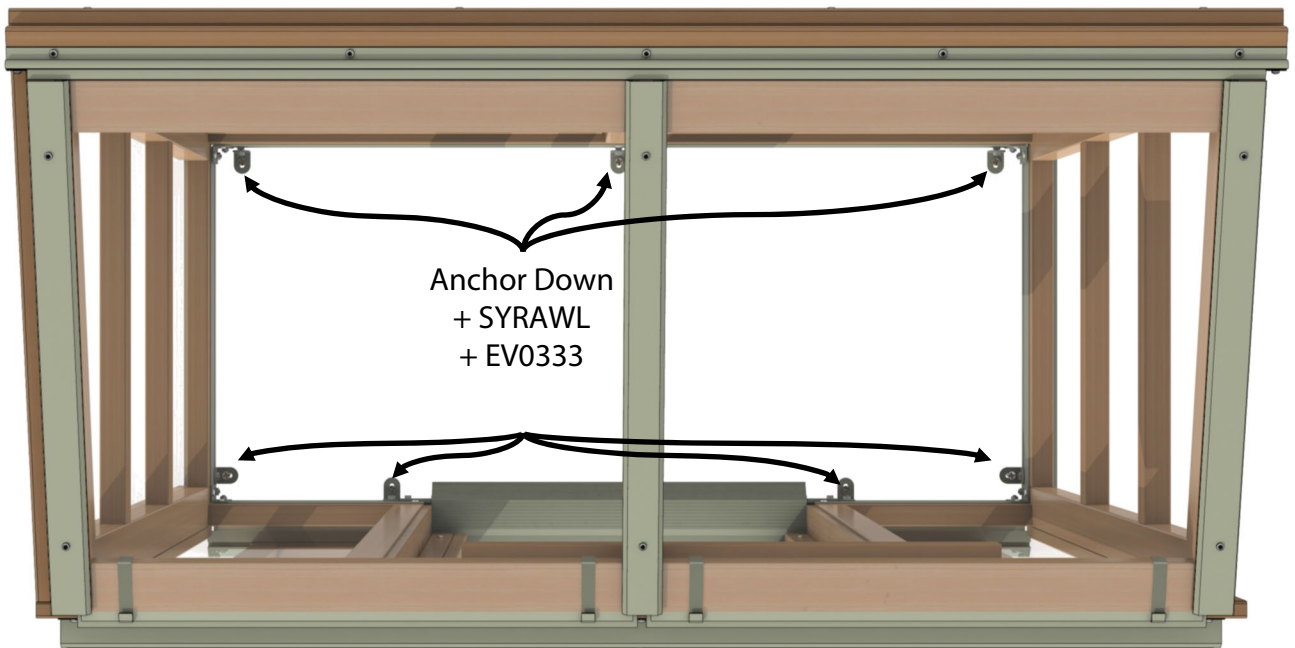

# Shelf Insertion

Now that you are nearing completion you can now anchor down the cold frame using the 2" rawl plugs and 50mm screws supplied. It is best to do this now before the shelves go in so you have better access to the inside.

Once anchored down you can with the help of an assistant slide in the four shelves 'EV0871' from the still unglazed right hand end gable. If you need to remove any shelves so as to grow from the ground it is most easily done by removing a side pane again for internal access.

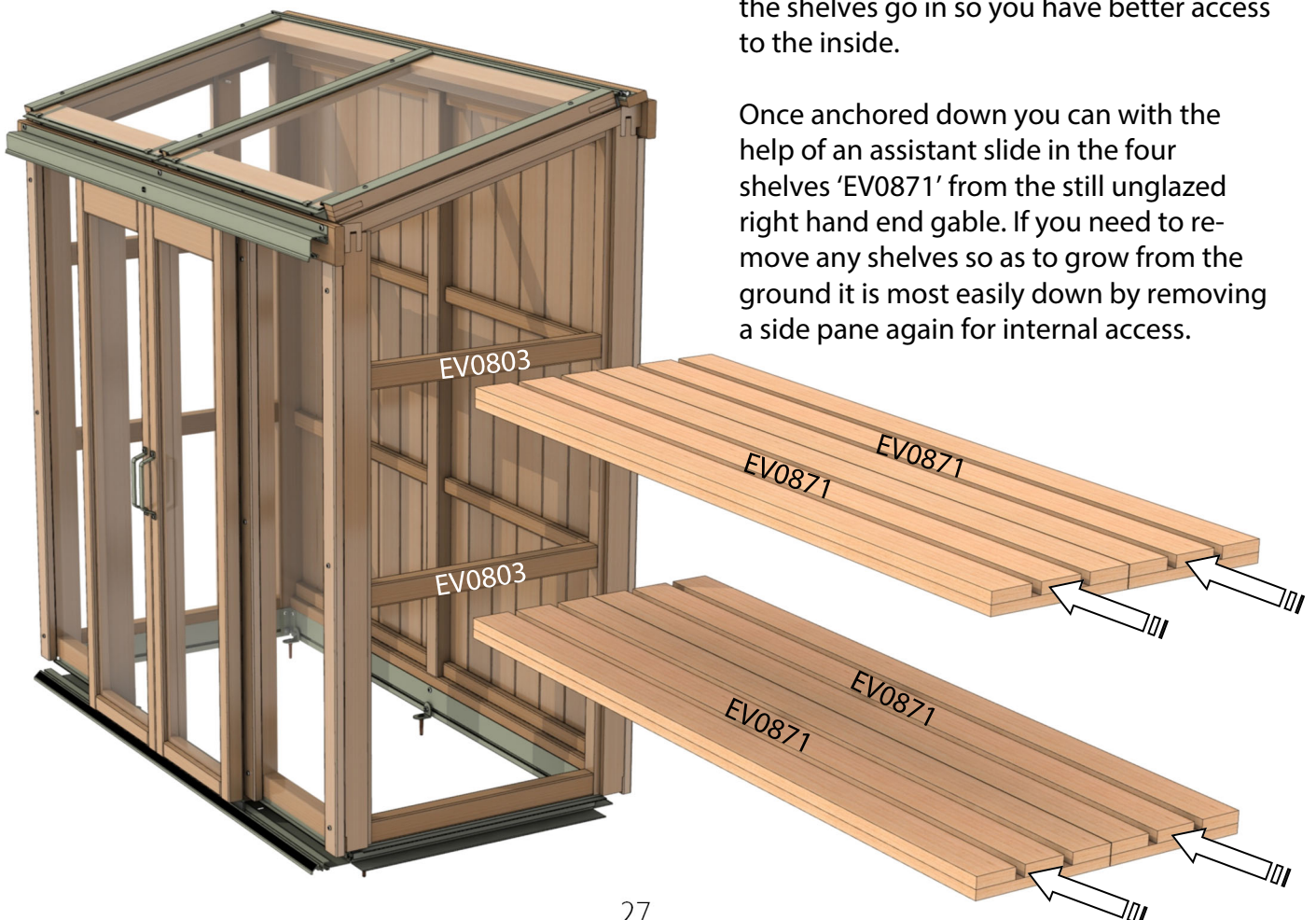

# Finish Glazing

Insert the right trapezium shaped side pane and fix the side cloaking board 'EV0826' with three 40mm Pan Head screws to hold it in place. Line this up with the top edge and the front face of the front top rail.

Now fit the right end capping strips 'EV0840' and 'EV0852', push these tight up against the underside of the cloaking board and fix each with three 25mm Pan Head screws.

If you need to adjust or remove your shelving at any time this is the best way to access the inside of the frame.



# Autovent attachment (optional)



Use four 25mm pan head screws to attach your double spring Thermoform autovent to fix the upper bracket to the bottom of the vent middle glazing bar and the bottom bracket to the underside of the front eaves rail 'EV0806'.



# Packing List

## Tall Evo Cold Frame

PART CODE	PART DESCRIPTION	LENGTH	MATERIAL	EXTRUSION	QUANTITY
D225	Door Glide 610mm	610	Plastic	N/A	2
EV0251M	ALU Roof Vent Capping EV0251 596mm **MOSS**	596	Aluminium	EX403	2
EV0280M	Double Door track for 5ft wide Evo model **MOSS**	1300	Aluminium	EX309	1
EV0283M	ALU Bottom Door Guide Single EV0283 1240mm **MOSS**	1240	Aluminium	R130	1
EV0285M	ALU Door Threshold Single EV0285 564mm **MOSS**	564	Aluminium	R007	1
EV0287M	ALU Door Cill Single EV0287 586mm **MOSS**	586	Aluminium	R174	1
EV0302M	ALU Side Base 4ft long EV0302 1211mm **MOSS**	1211	Aluminium	EX401	1
EV0311M	ALU Base Joining Bracket EV0311 60mm **MOSS**	60	Aluminium	EX005	4
EV0317M	ALU Door Top Bracket 315 EV0317 315mm **MOSS**	315	Aluminium	EX310	2
EV0319M	ALU Door Guide Bracket 315 EV0319 315mm **MOSS**	315	Aluminium	EX119	2
EV0320M	ALU Door Guide Bracket 620 EV0320 620mm **MOSS**	620	Aluminium	EX005	2
EV0800	Cold Frame Rear Cill 4ft EV0800 1222mm	1222	Cedar	32x44	1
EV0801	Tall Cold Frame Front Cill EV0801 318mm	318	Cedar	32x44	2
EV0803	Cold Frame Side Cill 2ft EV0803 545mm	545	Cedar	32x44	6
EV0806	Tall Cold Frame Front Top Rail EV0806 1310mm	1310	Cedar	44x69	1
EV0807M	ALU Tall Coldframe Front Base wide EV0807 315mm **MOSS**	315	Aluminium	EX401	2
EV0808	Cold Frame Rear Top Rail 4ft EV0808 1310mm	1310	Cedar	44x69	1
EV0811	Cold Frame Side Top Rail Left 2ft EV0811 600mm	600	Cedar	44x44	1
EV0813	Cold Frame Side Top Rail Right 2ft EV0813 600mm	600	Cedar	44x44	1
EV0823	Tall Cold Frame Front Post EV0823 1109mm	1109	Cedar	44x44	2
EV0824	Tall Cold Frame Rear Center Post EV0824 1263mm	1263	Cedar	44x44	1
EV0826	Cold Frame Side Cloaking Board 2ft EV0826 664mm	664	Cedar	19x69	2
EV0827	Tall Coldframe Front / Rear Cloaking Board EV0827 1348mm	1348	Cedar	19x69	2
EV0832	Cold Frame Top Hinge Board 4ft EV0832 1348mm	1348	Cedar	19x44	1
EV0834M	Double Vent Capping EV0834M 596mm **MOSS**	596	Aluminium	EX402	1
EV0835M	Cold Frame Top Hinge 4ft EV0835M 1348mm **MOSS**	1348	Aluminium	EX406	1
EV0836M	ALU Double Vent Hinge EV0836 1304mm **MOSS**	1304	Aluminium	EX407	1
EV0839	Tall Coldframe Side Capping Front Left EV0839 1108mm	1108	Cedar	19x69	1
EV0840	Tall Coldframe Side Capping Front Right EV0840 1108mm	1108	Cedar	19x69	1
EV0841M	Cold Frame Side Base 2ft EV0841M 531mm **MOSS**	531	Aluminium	EX401	2
EV0842	Tall Coldframe Rear Panel Rebated Capping EV0842 1258mm	1258	Cedar	19x44	2
EV0843	Tall Coldframe Front Capping EV0843 1091mm	1091	Cedar	19x44	4
EV0846	Tall Coldframe Rear Panel Capping EV0846 1258mm	1258	Cedar	19x44	1
EV0850	Tall Coldframe Side Capping Rear Left EV0850 1257mm	1257	Cedar	19x69	1
EV0852	Tall Coldframe Side Capping Rear Right EV0852 1257mm	1257	Cedar	19x69	1
EV0854	Door Rebate R EV0854 1072mm	1072	Cedar	19x69	1
EV0855	Door Rebate L EV0855 1072mm	1072	Cedar	19x44	1
EV0856	Cold Frame Lid Support EV0856 600mm	600	Cedar	19x44	1
EV0857	Tall Coldframe Door Frame Side EV0857 1106mm	1106	Cedar	11 x 57	2
EV0860	Tall Cold Frame Front Corner Post Left EV0860 1135mm	1135	Cedar	44x69	1
EV0861	Tall Cold Frame Front Corner Post Right EV0861 1135mm	1135	Cedar	44x69	1
EV0862	Tall Cold Frame Rear Corner Post Left EV0862 1290mm	1290	Cedar	44x69	1
EV0863	Tall Cold Frame Rear Corner Post Right EV0863 1290mm	1290	Cedar	44x69	1

# Packing List

<b>Smalls Pack for Alton Evolution Tall Cold Frame 2ft x 4ft</b>		
<b>PART CODE</b>	<b>PART DESCRIPTION</b>	<b>QUANTITY</b>
D174M	Base bracket D174 ***MOSS***	7
D220	Vent Hinge Stop	2
FS6060	M4 x 12 Pan/Pozi Machine Screw S/Steel	2
EV0290M	ALU Door Handle EV0290 **MOSS**	2
EV0311M	ALU Base Joining Bracket EV0311 60mm **MOSS**	4
EV0313M	Glass Stop EV0313 **MOSS**	4
EV0328	19mm x 4 Pan Pozi	10
EV0331	25mm x 4 Pan Pozi	48
EV0332	40mm x 4 Pan Pozi	45
EV0333	50mm x 5 Csk pozi	16
EV0334	80mm x 5 Csk pozi	15
EV0337	4mm Drill Bit	1
SYBOLM6X11	Bolts 11mm M6	10
SYBOLM6X11CROP	M6X 11mm Cropped Head Bolts	7
SYNUTM6	Nuts M6 Alu	17
02-1898	Washer 1/4in Table 4 Light Zp	2
HE512M	Cill joining bracket 64mm EX120 **MOSS**	2
SYWHEELS	Door wheels (Simp) Part no 791467	4
SYBOLDOOR	Door Wheel Brass Bolt	4
SYNUTDOOR	M5 Hex Nylon Lock Nut	4

<b>Preassembled Sections</b>			
<b>PART CODE</b>	<b>PART DESCRIPTION</b>	<b>SIZE</b>	<b>QUANTITY</b>
EV0870	Tall Cold frame Door Assembled 315 EV0870	315x1105	2
EV0871	Tall Cold frame Shelf	239x1286	4
EV0872	Double Vent Assembly	596x1304	1
EV0873	Tall Cold frame Rear Panel	610x1271	2

<b>Glass Sizes</b>		
<b>PART CODE</b>	<b>PART DESCRIPTION</b>	<b>QUANTITY</b>
EV243X1009	243x1009	2
EV298X1118	298X1118	2
EV509X1277X1141	509X1277X1141 TRAPEZIUM	2
610X610	610X610	2

# Completed Assembly



Your glazed cold frame is now complete!



**Alton Greenhouses**, TGP Ltd, Blythe Park, Cresswell, Stoke-on-Trent, ST11 9RD

Telephone: 01782 385 409 [www.Altongreenhouses.co.uk](http://www.Altongreenhouses.co.uk) [sales@altongreenhouses.co.uk](mailto:sales@altongreenhouses.co.uk)